

NHK MEC

KE-4a

ELECTRONIC CONTROL SYSTEM

INSTRUCTION MANUAL

TABLE OF CONTENTS

INTRODUCTION	1
SAFETY PRECAUTIONS	1
INSTALLATION / REPAIR	1
PRODUCT COMPLIANCE	2
PRODUCT SPECIFICATIONS	2
NAME OF EACH PART	3
COMPONENTS LIST	4
CONTROL UNIT DETAILS	5
CONTROL HEAD DETAILS	6
ACTUATOR DETAILS	7
KE SYSTEM OPERATION	8
Initial Control operation After Power “ ON “	8
Control Head Lever Operation	8
Neutral Throttle Operation	9
Station Transfer for 2, 3 and 4 Station Operation From A Neutral Position	9
Station Transfer for 2, 3 and 4 Station Operation From A Forward Throttle Position	9
DETERMINATION OF CABLE LENGTH	10
INSTALLING THE CONTROL HEAD	11
INSTALLING THE CONTROL UNIT	12
INSTALLING THE ACTUATOR	13
CONNECTING THE CONTROL HEAD AND CONTROL UNIT	14
CONNECTING THE ACTUATOR AND CONTROL UNIT	15
CONNECTING SIGP: START-IN-GEAR PROTECTION	16
CONNECTING POWER	17
CONNECTING THE COMMUNICATION HARNESS	18
CONNECTING THE DIM HARNESS (OPTION)	19
OVERALL WIRING DIAGRAM	20
PUSH-PULL CABLE INSTALLATION	21
ADJUSTING THE CONTROL UNIT	23
● Throttle actuator mode	24
● Forward throttle stroke	24
● Forward throttle opening	24
● Reverse throttle stroke	25
● Shift actuator mode	25
● Shift stroke : Forward	25
● Shift stroke : Reverse	25

TABLE OF CONTENTS (continued)

● Throttle delay	26
● Shift pause	26
OPERATION CHECK	27
● Shift and throttle operation check	27
● Confirmation of the engine start	27
MANUAL OPERATION METHOD (OPTION)	28
ALARM CODES	29
TROUBLESHOOTING	32
MAINTENANCE AND SERVICE	33
CONTROL HEAD TEMPLATE	35
CONTROL UNIT TEMPLATE	37

INTRODUCTION

This manual has been prepared to ensure your correct operation of the KE-4a system. Be sure to read through this manual to understand the content thoroughly with care to prevent injury or damage to the property through abuse. Always keep the manual within your reach during operation.

This product controls the shift(clutch) and throttle(governor). It is recommended therefore to read the manual of engine and clutch.

The specifications may be subject to change without notice in view of improvement, resulting in more or less difference between the content of the manual and the product. In case of ambiguity or questions concerning the product or the manual, consult with your dealer.

SAFETY PRECAUTIONS

This manual contains precautions under the following headers, which, if not observed, may result in injury or damage to the property. Pay particular attention on these precautions.



Failure to comply with a Warning may result in an accident of death or heavy injury.



Failure to comply with a Caution may result in an accident of light injury or damage to the product or properties.

INSTALLATION / REPAIR

The installation of this product must be performed following all applicable installation and safety codes.

Only authorized personnel should perform disassembly and repair of this product; otherwise the warranty will be voided.

PRODUCT COMPLIANCE

1. EUROPEAN UNION



RECREATIONAL CRAFT DIRECTIVE
EMC DIRECTIVE

2. USCG

This control system provides start-in-gear protection meeting USCG requirements of 33 CFR Part 183, Subpart L.

3. ABYC, ISO

This control system meets applicable ABYC & ISO standards.

PRODUCT SPECIFICATIONS

1. Electric Performance

- Supply voltage: For DC12V model: DC9V~16V; For DC24V model: DC16V~30V
- Max. current of actuator:16A or less(at 49N{5kgf} · 11lbf load)
- Current consumption at stop of actuator:0.5A or less

2. Mechanical Performance (Actuator)

- Thrust: Max.operating thrust:147N{15kgf} · 33lbf
Constraint load :343N{35kgf} · 77lbf
- Shift: Forward stroke 26·30·34·40mm; Reverse stroke 26·30·34·40mm
(can be set separately).
- Throttle: 80mm MAX

3. Temperature Range

- Operating temperature:-20~+75 ° C
- Storage temperature :-40~+100 ° C

4. Product Functions

- Shift: Forward/reverse operation
- Throttle: Acceleration/deceleration
- Neutral throttle: Only the throttle is activated to warm up the engine.
- Control Station: Max.4 stations
- SIGP: Enables engine start up only when the shift is in the neutral position.
- Dim display: Decreases luminance of the lamp on the control head in the nighttime.
- Alarm Codes: Detect system faults and indicate by the frequency of flashing of the pilot lamp of the control head.
- Mechanical back-up: Enables mechanical operation of the actuator when electrical failure makes operation from the control head impossible.

NAME OF EACH PART

The figure below shows an example of two engines / two control station system

- :Indicates Identification
- :Indicates the destination of connection

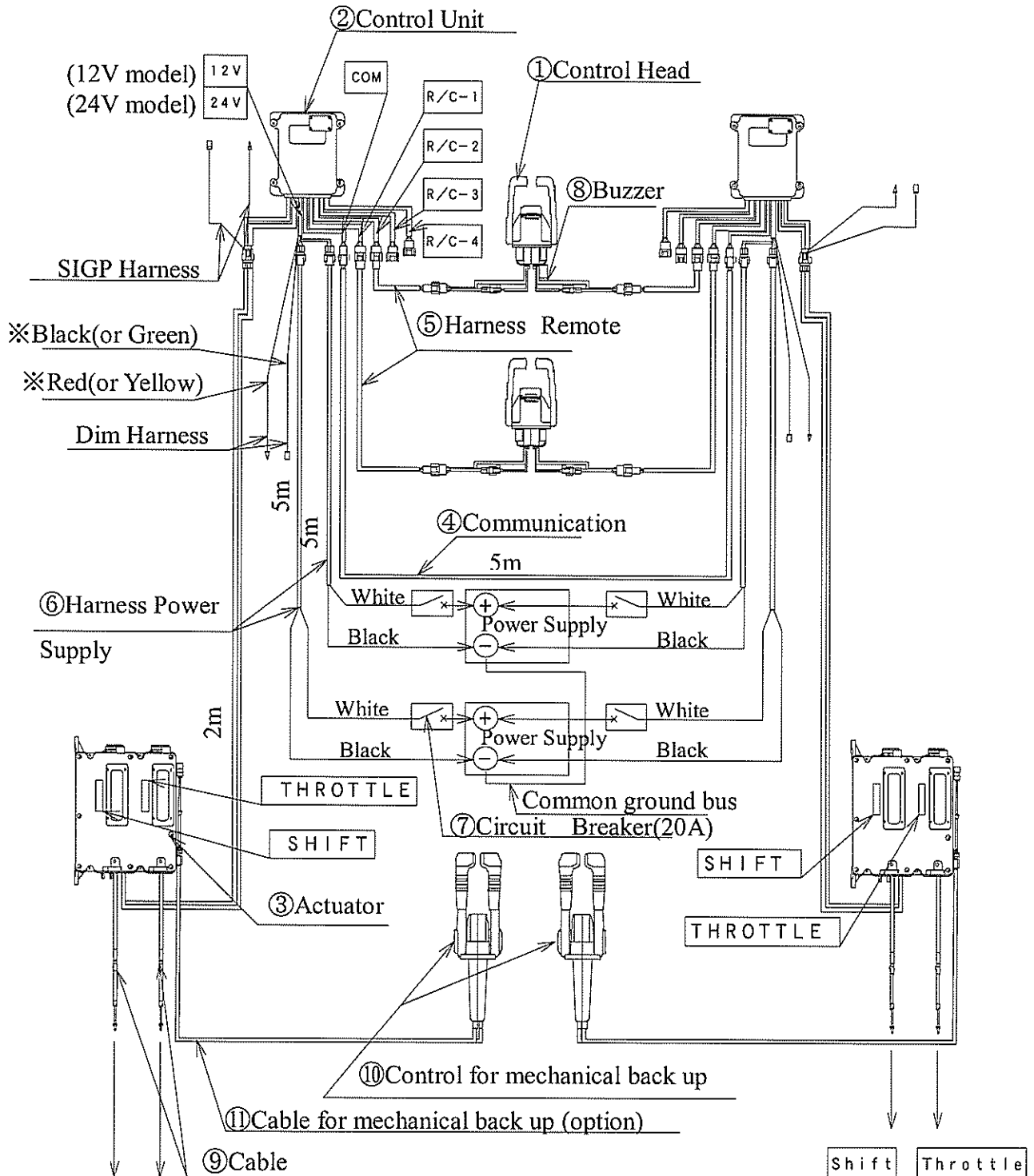

COMPONENTS LIST

No.	Name	Part No.	Required								Note
			Single engine				Two engine				
			No.of Station				No.of Station				
			1st	2nd	3rd	4th	1st	2nd	3rd	4th	
①	Control Head	NM0511-00	1	2	3	4	-	-	-	-	
		NM0510-00	-	-	-	-	1	2	3	4	
②	Control Unit 24Vmodel 12Vmodel	NM0478-00	1	1	1	1	2	2	2	2	
		NM0477-00									
③	Actuator	NM0165-00	1	1	1	1	2	2	2	2	
④	Communication harness 5m	NM0619-05	-	-	-	-	1	1	1	1	
⑤	Harness 4m	NM0616-04									For length other than those listed in the left, consult your dealer. 1m = 39.4 inches.
	Remote 6m	NM0616-06									
	Control 8m	NM0616-08									
	10m	NM0616-10									
	12m	NM0616-12									
	14m	NM0616-14									
	16m	NM0616-16									
	18m	NM0616-18									
	20m	NM0616-20									
	22m	NM0616-22	1	2	3	4	2	4	6	8	
	24m	NM0616-24									
	26m	NM0616-26									
	28m	NM0616-28									
	30m	NM0616-30									
	32m	NM0616-32									
34m	NM0616-34										
36m	NM0616-36										
38m	NM0616-38										
40m	NM0616-40										
50m	NM0616-50										
⑥	Harness 5m	NM0414-28	2	2	2	2	4	4	4	4	
	Power Supply 10m	NM0414-33									
⑦	Circuit Breaker 20A	NJ0514-00	2	2	2	2	4	4	4	4	Option
⑧	Buzzer 24Vmodel 12Vmodel	NJ0515-00	1	2	3	4	2	4	6	8	Option
		NJ0251-00									
⑨	Cable	TFXtreme	2	2	2	2	4	4	4	4	Specify the length
⑩	Mechanical Control Head	Use standard control head	1	1	1	1	2	2	2	2	Option
⑪	Cable (cable for manual operation)	TFXtreme	2	2	2	2	4	4	4	4	Option Specify the length

Note: Refer to the NAME OF EACH PART on previous page for identification of each part.

CONTROL UNIT

Note: The Control Unit is available in two types; one for 24V and the other for 12V. Select the appropriate one for your power supply.

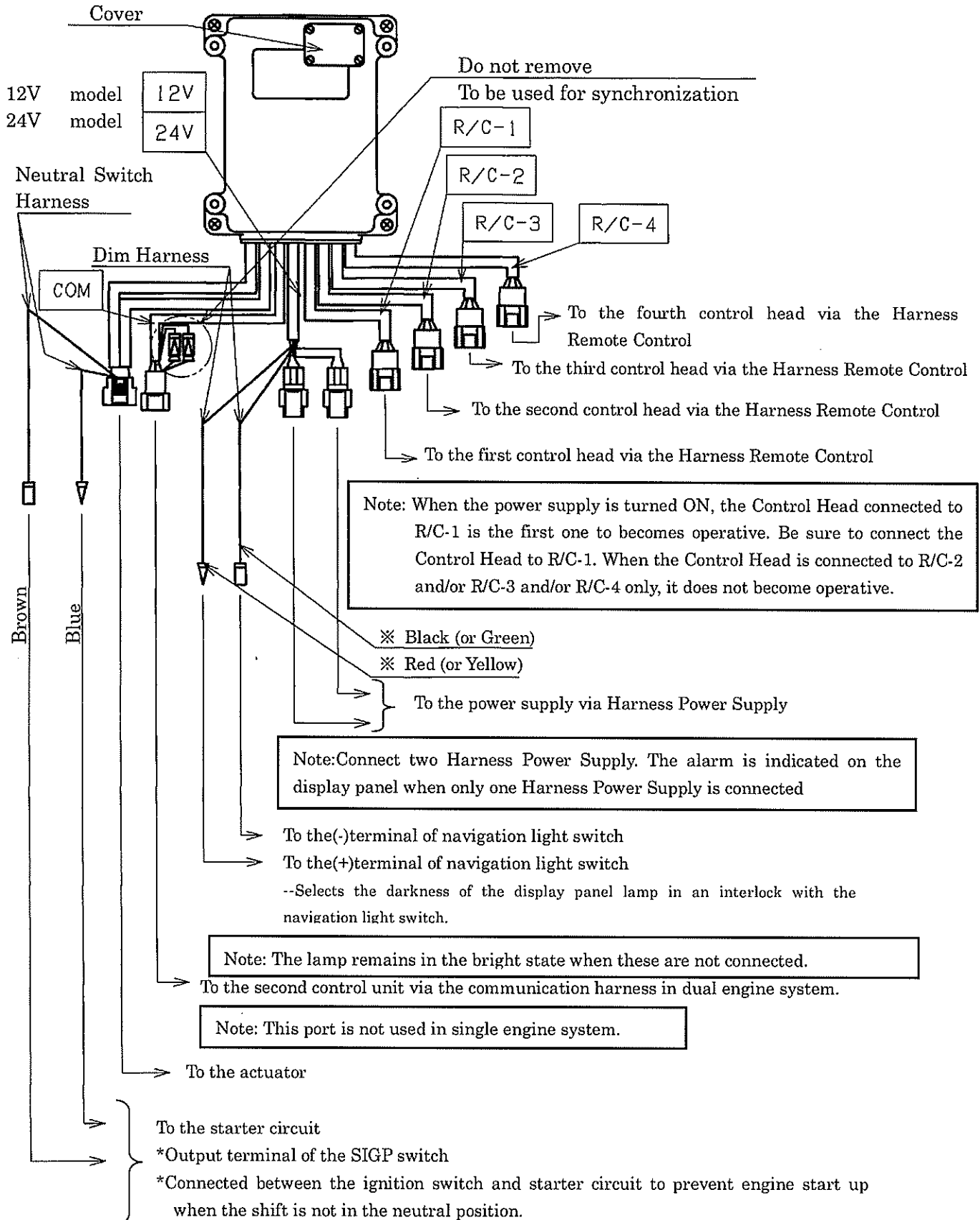

CONTROL HEAD

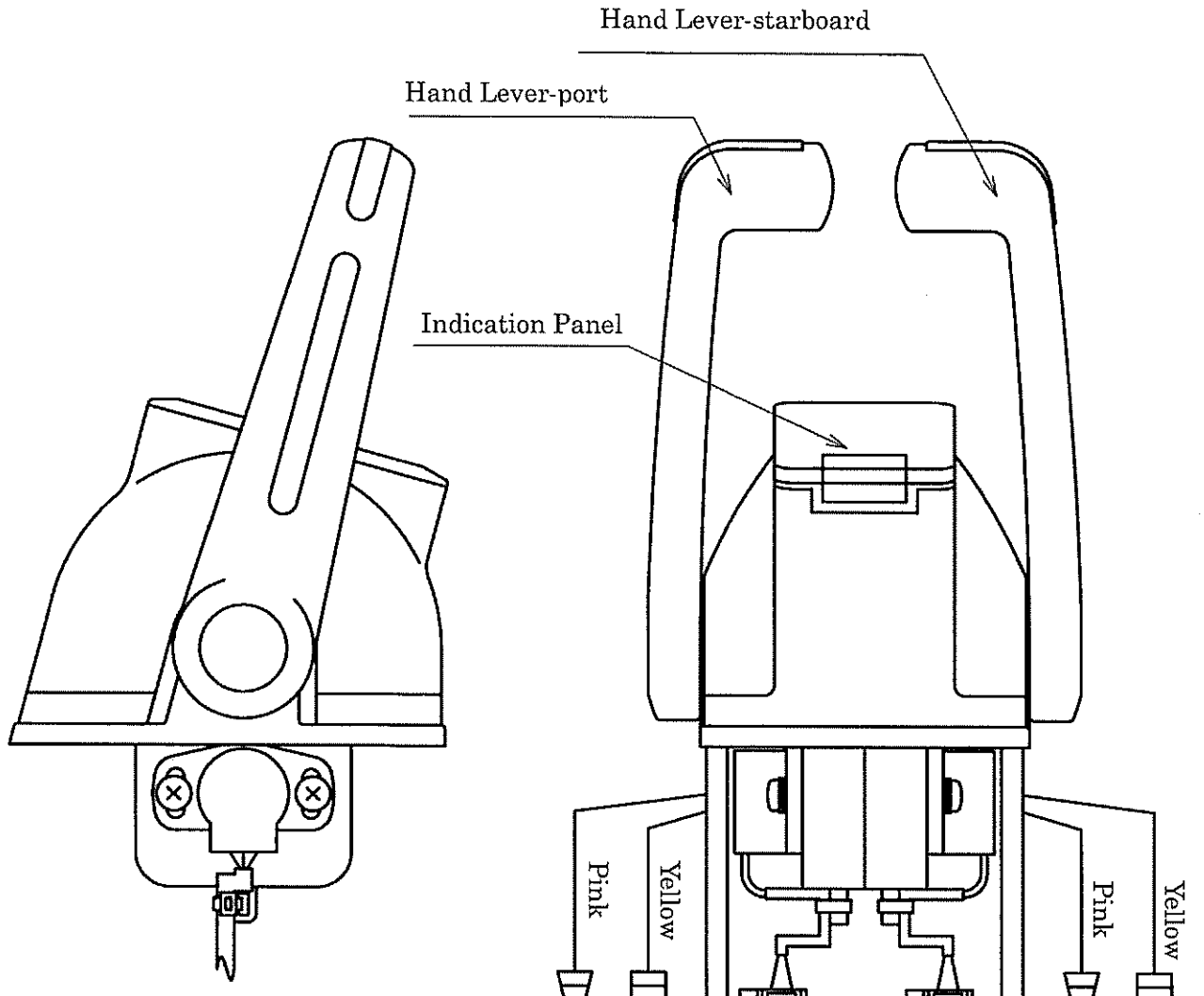

(1) Indicator Panel

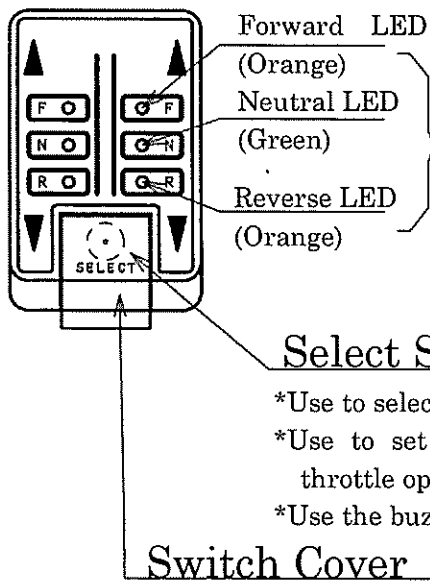

*Indicates the shift position with a LED
 *The neutral LED flashes during neutral throttle operation.
 *All LED's flash when the alarm is given.

Select Switch
 *Use to select the station.
 *Use to set or cancel the neutral throttle operation.
 *Use the buzzer.

Switch Cover

To the port Control Unit via
 Harness Remote Control

To the starboard Control
 Unit via Harness Remote
 Control

ACTUATOR



WARNING

Operate the Selector Knob only in case of emergency (mechanical backup)

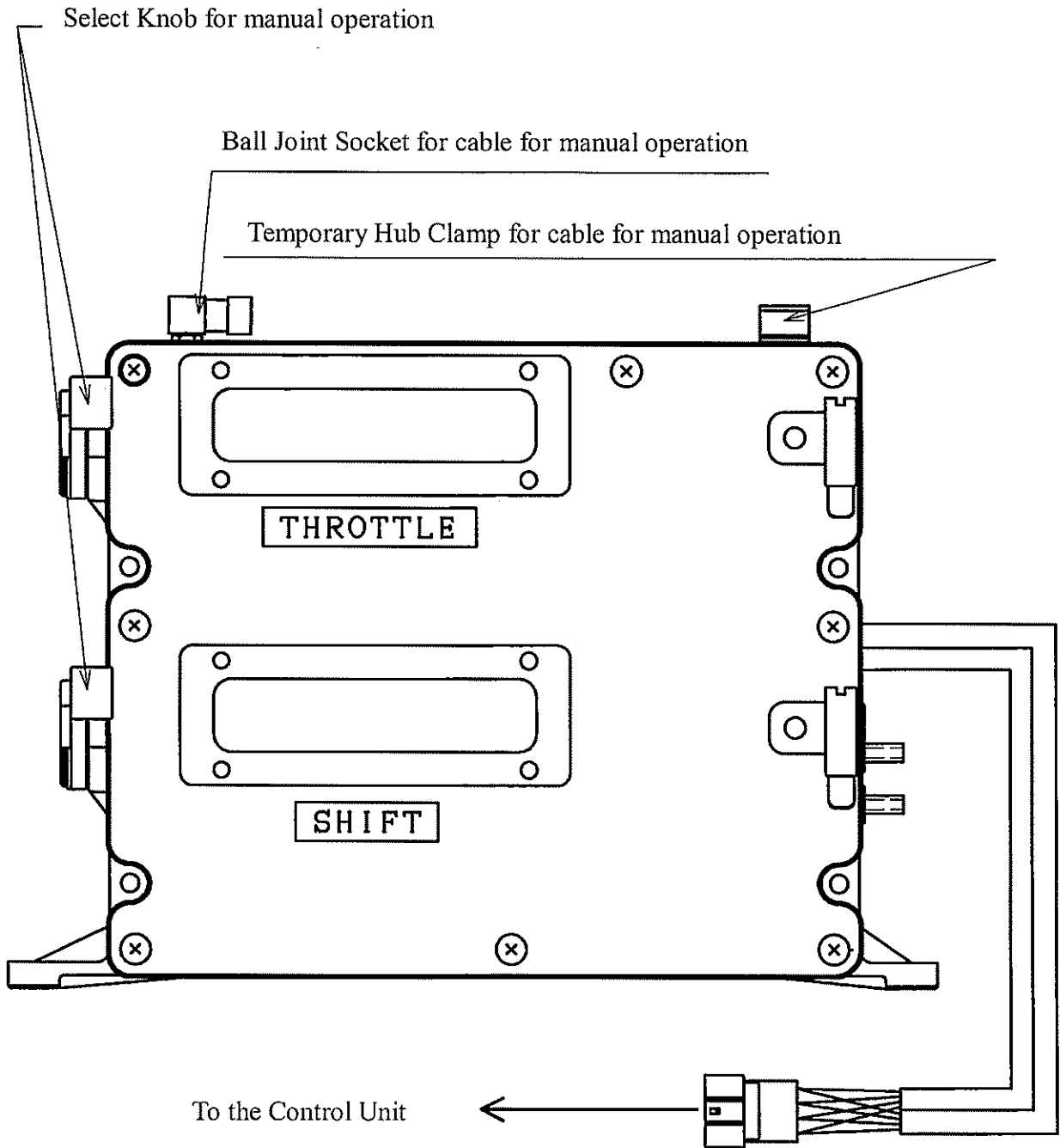

* The Actuator includes a throttle actuator and shift actuator

KE SYSTEM OPERATION

Initial Control Operation After Power “ ON “



1. With power “ ON “, and the hand lever in the “ Neutral “ position, the system will be in the neutral idle condition.
2. The control head connected to remote control connector one (R/C-1) is considered the master control station and will become operational first.
 - (A) Set the handle lever to the “ Neutral “ position.
 - (B) The green neutral LED (s) lights ON indicating the control is operational.

NOTE

If the hand lever(s) are moved to a forward or reverse gear position while power is not applied to the control system, and then power is applied, control system will not become operational until hand lever(s) are moved into the neutral position. The green neutral lamp(s) then lights indicating the control is operational.

3. When other control stations are required for operation that are connected to R/C-2, R/C-3 and R/C-4 perform the following actions.
 - (A) Set the hand lever to the “ Neutral “ position.
 - (B) Open the switch cover, press and release the select switch.
 - (C) The green neutral LED(s) then lights ON indicating the control is operational.

Control Head Lever Operation

 CAUTION
Never move the hand lever(s) while engine is not running. Otherwise actuator, cables, engine or shift mechanism could be damaged.
 WARNING
DO NOT ATTEMPT sudden forward to reverse the hand lever(s) operation. Sudden acceleration/ deceleration may cause damage to the boat or cause operator or passengers to be ejected from the boat.

- (1) Moving the hand lever from the neutral position to the forward or reverse detent causes the actuator to shift to forward or reverse gear. Orange forward or reverse LED(s) light ON to indicate forward or reverse gear position obtained.
- (2) Moving the hand lever past the Forward or reverse detent causes actuator into throttle operation and the boat will accelerate.

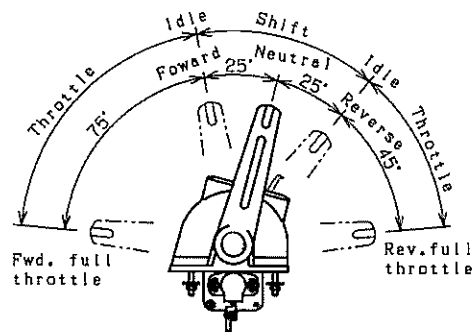

Neutral Throttle Operation

1. Set the hand lever to the " NEUTRAL " position.
2. Open the switch cover located on top the control head and move the hand lever to the forward gear position while pressing the station select switch.
3. The green neutral LED flashes and the neutral throttle operation are activated.
Neutral throttle operation will remain active until properly deactivated.

To Cancel Neutral Throttle Operation

1. Set the hand lever to the " NEUTRAL " position.
2. Open the switch cover and press and release the select switch.
After the release of the select switch green neutral LED will stop flashing indicating deactivation of the neutral throttle operation.

Station Transfer for 2,3 and 4 Station Operation From A Neutral Position

1. Set the hand lever(s) of the selected control to the neutral position, open the switch cover press and release the select switch. A continuous green neutral LED(s) indicates the control station is active.

Station Transfer for 2,3 and 4 Station Operation From A Forward Throttle Position

1. Set the hand lever(s) of the selected control to the neutral position, open the switch cover press and release the select switch. A continues green neutral LED(s) indicates the control station is active.
2. The operator has 4 seconds to move hand levers and match the throttle position of the last active control station. Continuous orange forward LED(s) indicates control station is active.

NOTE

Keeping the hand lever of the last active control station in the neutral position, will result in control system automatically returning the control system to a neutral idle condition.

Continuous green neutral lamp(s) indicates the control station active and system is a neutral idle condition.

DETERMINATION OF CABLE LENGTH



CAUTION

Do not bend the cable less than the specified radius.
Otherwise, the cable or actuator may be damaged.

Measure the distance from the shift and throttle actuator to the engine's shift and throttle connection position in as straight a line as possible while avoiding any obstruction, which may cause bending of less than the specified radius. This distance becomes a guideline to determine the cable length.

For outboard motors, determine the cable length as determined above plus 1-1.5m to make up a loop shown below.

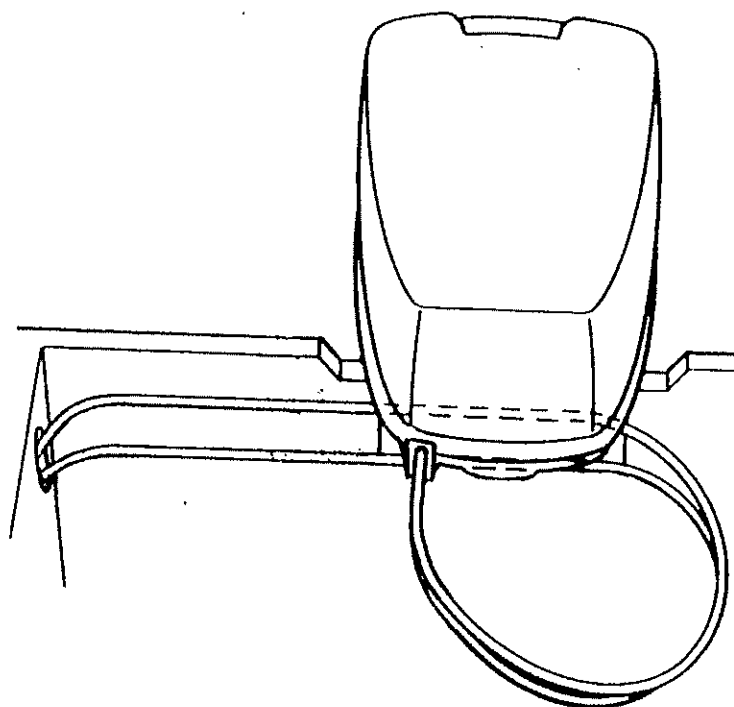

Be aware of push-pull cable
bending radius specification.

INSTALLING THE CONTROL HEAD



CAUTION

Install the control head in a location such that the engine can be stopped anytime.

Select a flat location convenient for operation and installation.

- (1) Drill mount holes by using an attached template.
- (2) Install with attached washers and nuts.

Tightening torque : 2.9 ~ 4.4 N · m (2.1 ~ 3.2 lbf · ft)

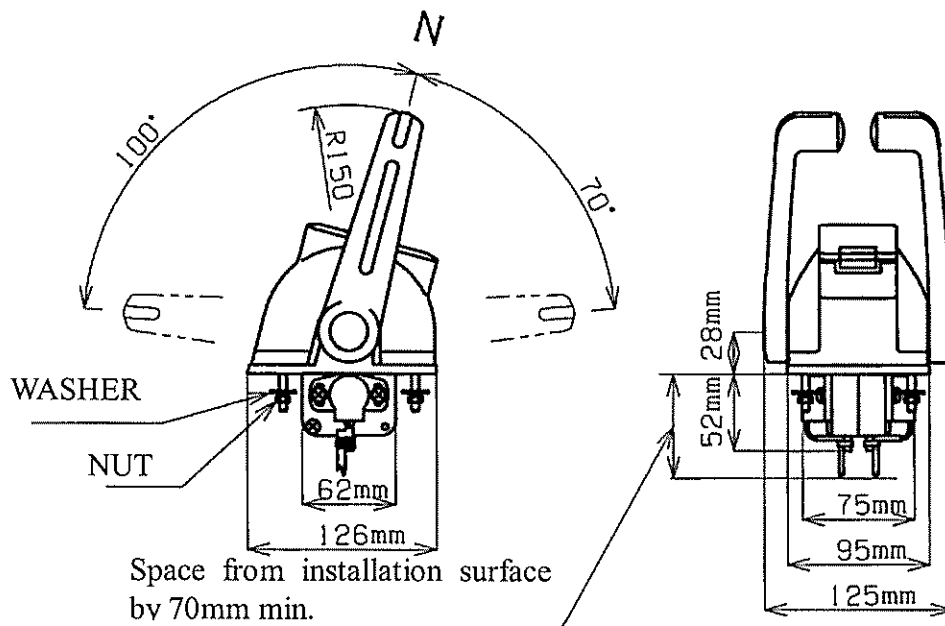

CAUTION

Mount the control head within 60 degrees from horizontal.

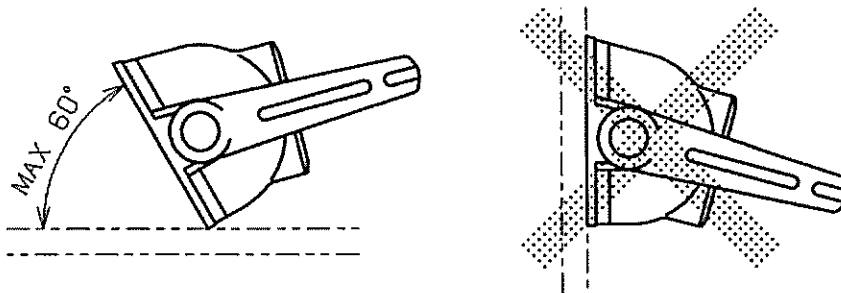

INSTALLING THE CONTROL UNIT

 CAUTION

1. Ingress of water into the unit may cause failure
2. Install so that harnesses exit through the bottom and the small cover faces up for easy access to DIP switches.
3. Install in a location where sea wind and water effects are minimized.
4. Avoid a location where the ambient temperature exceeds 75°C.

Instructions:

- (1) The actuator harness is 2m in length. Select the control unit location so that its distance from the actuator is 2m or less.
- (2) Drill the mount hole by using an attached template.
- (3) Install with attached pan head machine screw or tapping screw.

Installation with pan head machine screw

Installation plate thickness : 3 ~ 20 mm (1/8 ~ 3/4 in.),

Mount hole dia : ϕ 7 mm (ϕ 1/4 in.)

Tightening torque : 4.9 ~ 7.8 N · m (3.6 ~ 5.7 lbf · ft)

Installation with tapping screw

Installation plate thickness : 1.5 mm min. (5/8 in. min.),

Pilot hole dia : ϕ 3 mm (ϕ 1/8 in.).

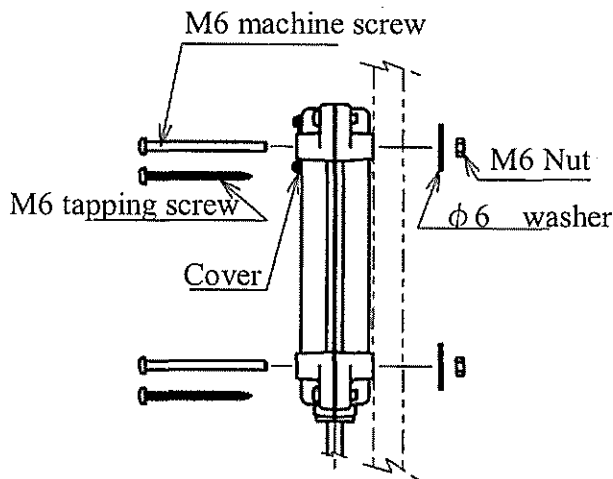

INSTALLING THE ACTUATOR



CAUTION

1. Ingress of water into the unit may cause failure.
2. Install in a location convenient for access to manual operation selector knob.
3. Install in a location where sea wind & water effects are minimized.
4. Avoid a location where the ambient temperature exceeds 75°C.

Instructions:

1. The actuator harness is 2m (6.5ft) in length. Select the actuator location so that its distance from the control unit is 2m (6.5ft) or less.
2. Drill mounting hole locations based on the installation type A (vertical) or B (horizontal) as per the drawings below.
3. Install with included fasteners or with separately purchased machine screws or tapping screw and washer (see data below).
4. Tighten to 3.9 ~ 5.9 N · m (2.9 ~ 4.3 lbf · ft) of torque.

Notes:

1. Fastener mounting plate thickness : 20mm min. (3/4in. min),
2. Pilot hole diameter : ϕ 5mm (ϕ 1/5in.)

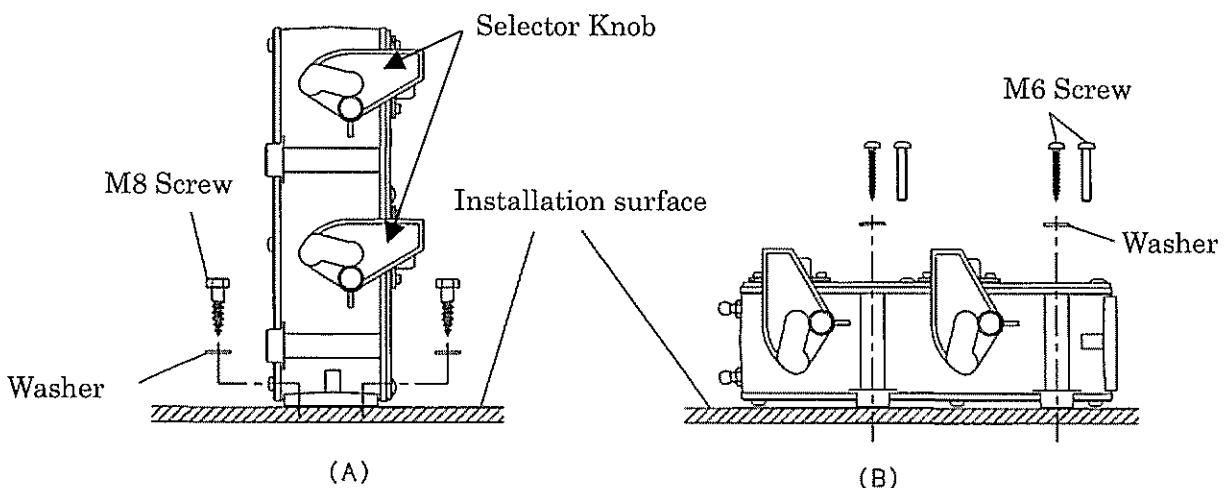

CONNECTING CONTROL HEAD & CONTROL UNIT



CAUTION

1. All connectors must be mated firmly; the system may fail to operate otherwise.
2. Be sure to connect a control head to R/C-1. When power is applied, the control head connected to R/C-1 is the first one to become operative.

(1) Connection of the first control head

Connect the harness remote control to the red-taped harness of the control head and connect it to R/C-1 of the port control unit. Connect the harness remote control to the green-taped harness of the control head and connect it to R/C-1 of the starboard control unit.

(2) Connection of the second control head if applicable

Carry out connection to the R/C-2 of each control as described in (1).

(3) Connection of the third control head if applicable

Carry out connection to the R/C-3 of each control as described in (1).

(4) Connection of the fourth control head if applicable

Carry out connection to the R/C-4 of each control as described in (1).

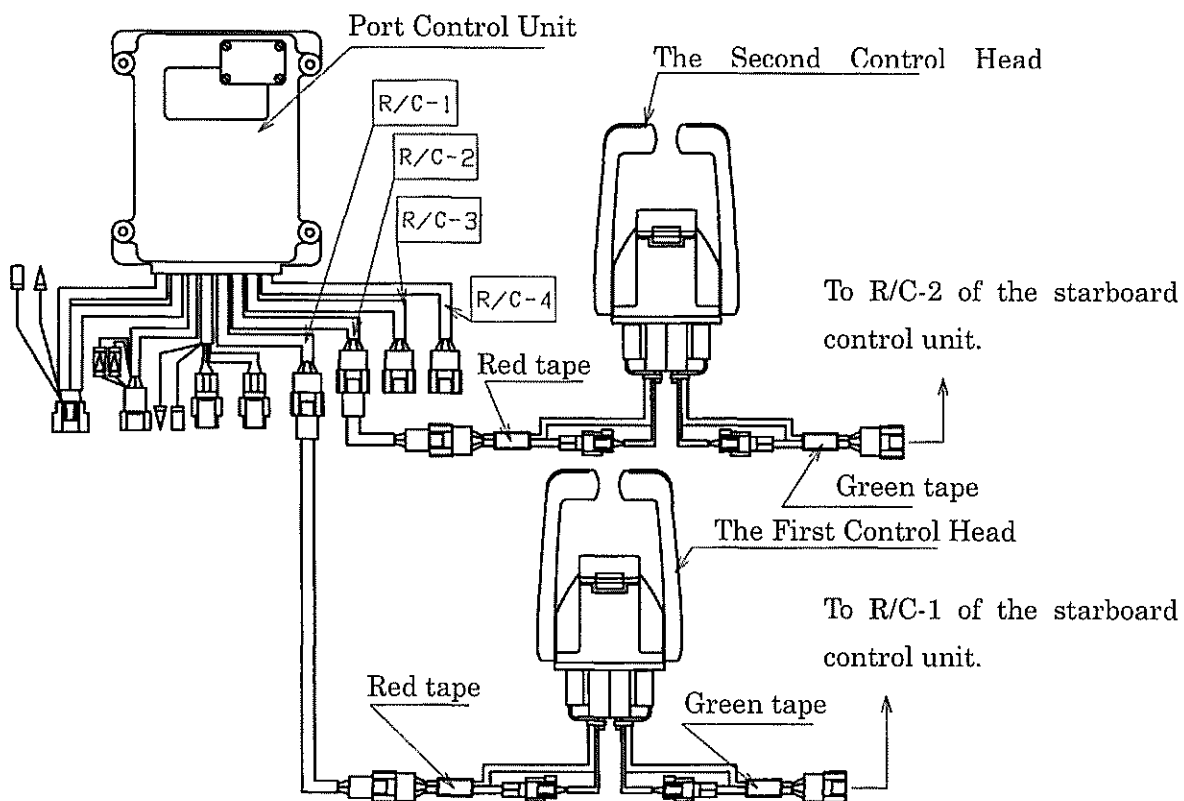

CONNECTING ACTUATOR & CONTROL UNIT

Connect the 12-pole coupler of the actuator to that of the control unit.

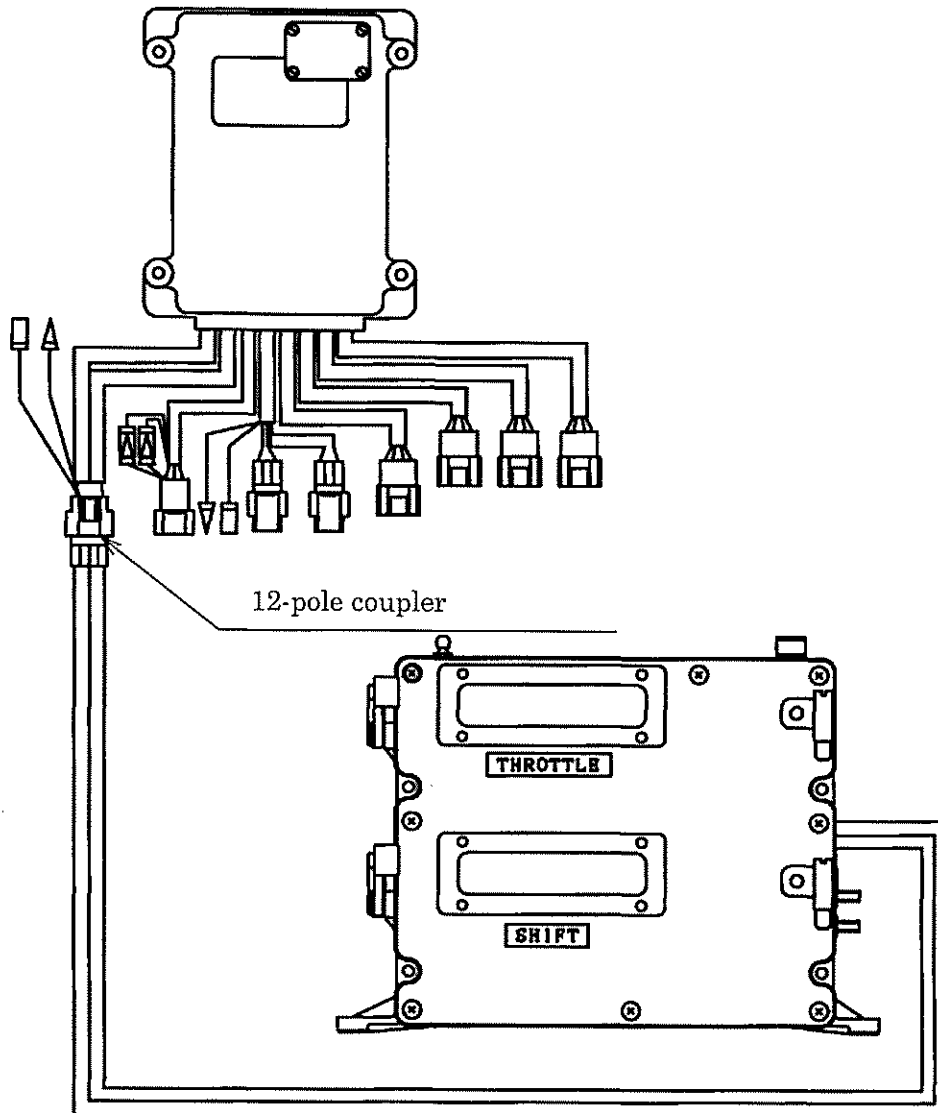

CONNECTING SIGP: START-IN-GEAR PROTECTION

Instructions:

1. Connect between the starter circuit and the ignition switch of the boat.
2. Select extension wires that are as thick (2mm^2 / 14AWG or more) and short as possible; excessively long extensions could cause voltage drop, resulting in failure of engine start.

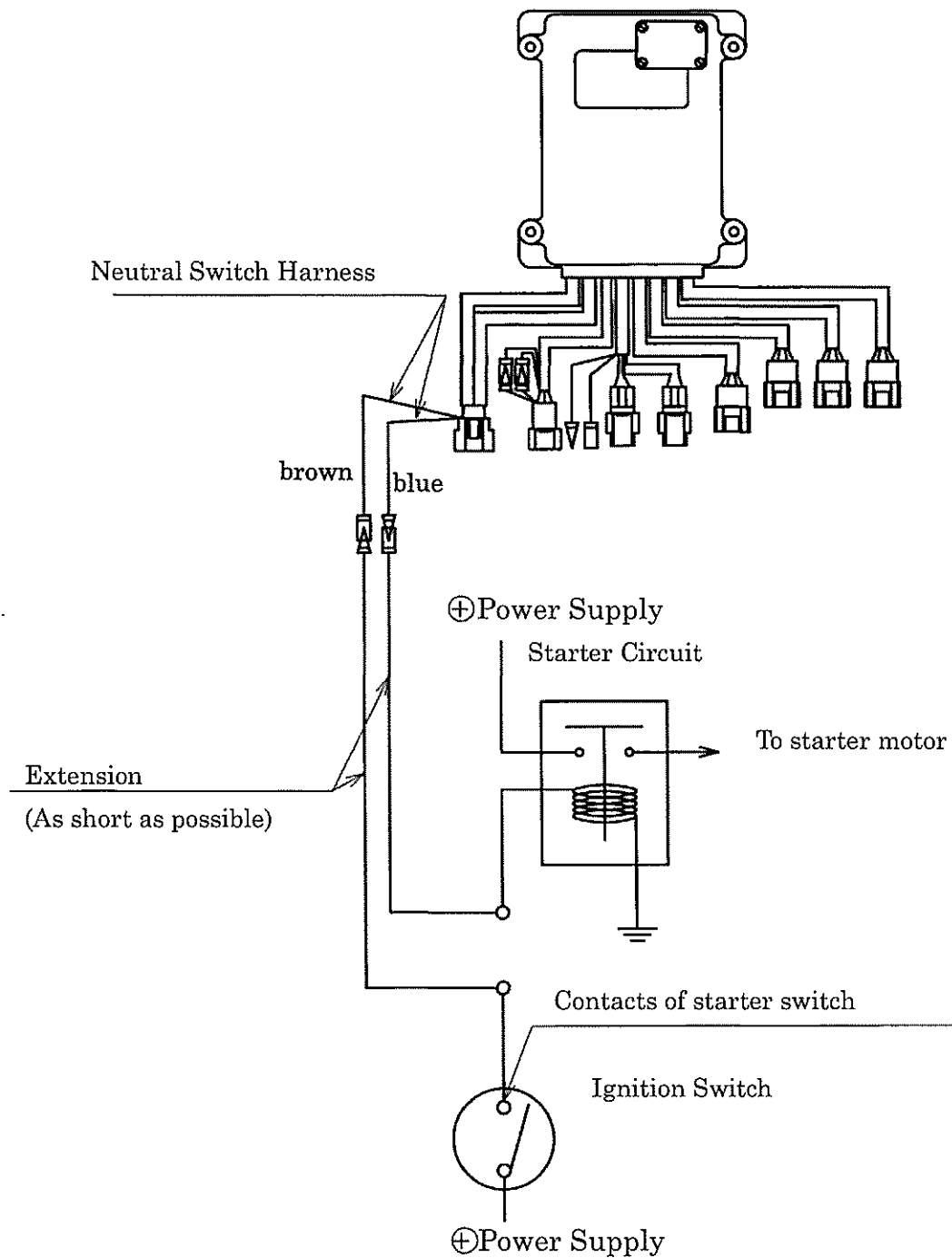

CONNECTING POWER



CAUTION

1. As a safety feature, a duplex power line system is provided. Be sure to connect both lines. Alarm code LED's will flash if only one power line is connected.
2. Once the power harness is connected to power (battery), do not attempt to disconnect the power harness from the control unit unless power is first disconnected via circuit breaker or battery switch.

Instructions:

1. Connect the system power harnesses to the control unit before connecting each power harness to battery (power supply).
2. Connect each black wire of the power harness directly to (- minus) of battery (power).
3. Connect each white wire of the power harness, via the optional 20 amp circuit breaker, via the boat circuit breaker or directly to (+ plus) of battery (power).

Note: If two batteries are provided, it is recommended to separate the power lines and connect one (plus breaker) to each battery.

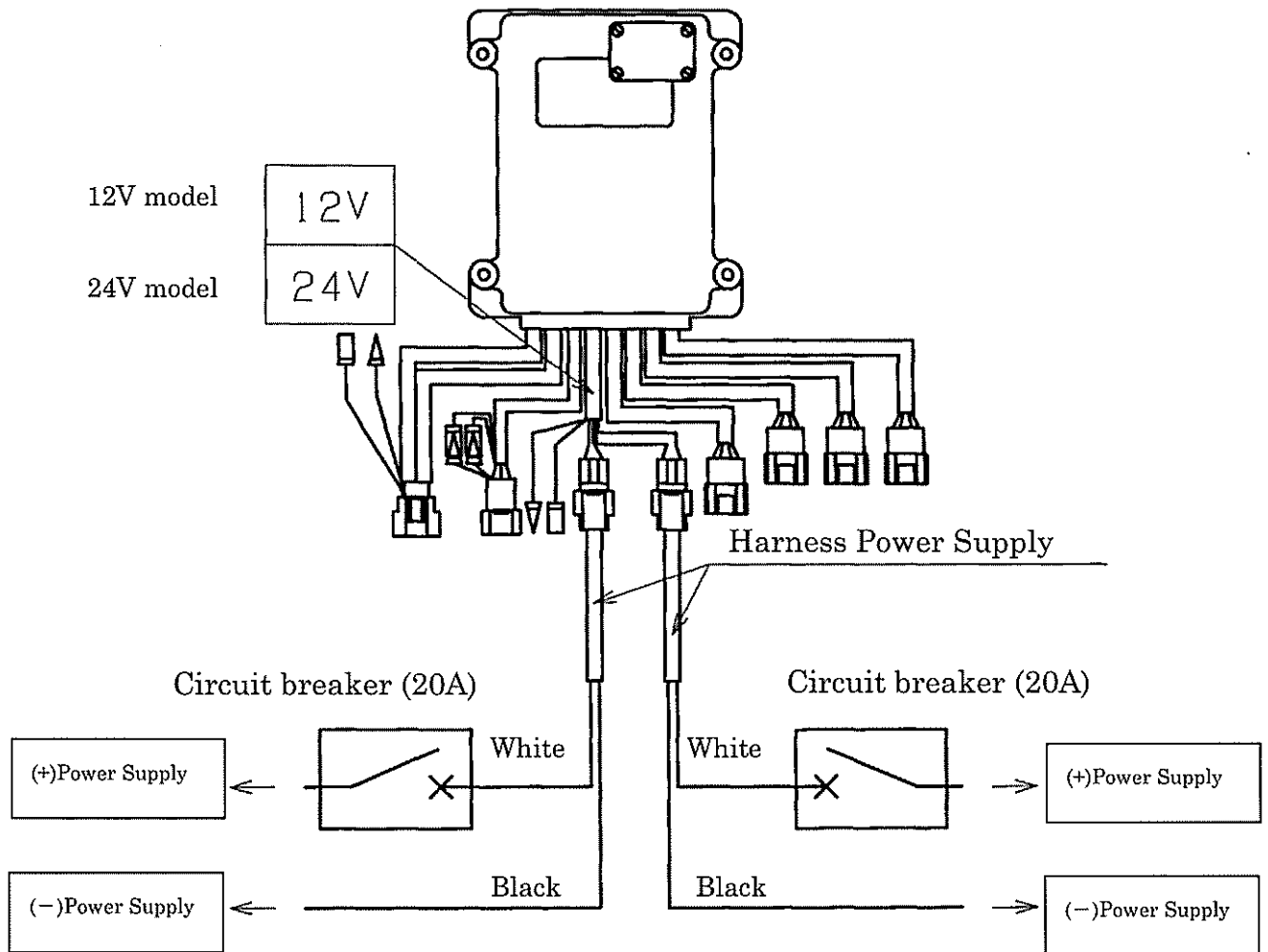

CONNECTING THE COMMUNICATION HARNESS

⚠ CAUTION

Turn off circuit breaker or battery switch before connecting or disconnecting the communication harness from the control unit.

Connect the two control units via the communication harness, which has 10-pole couplers at the both end, in dual engine system.

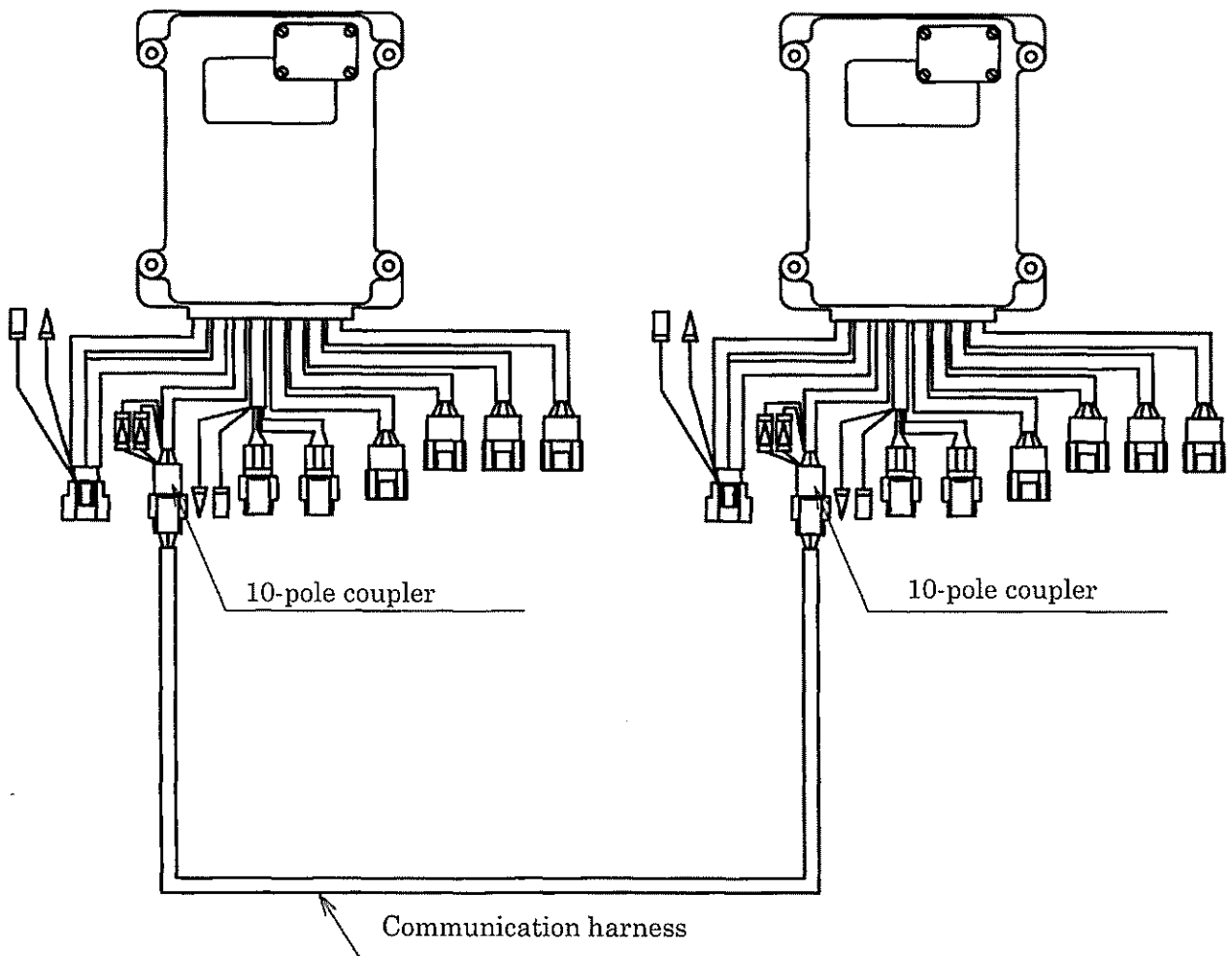

CONNECTING THE DIM HARNESS (OPTION)

- (1) Connect the Dim Harness Red(or Yellow) line to the plus (+) wire of navigation light.
- (2) Connect the Dim Harness Black(or Green) line to the minus(-) wire of navigation light.

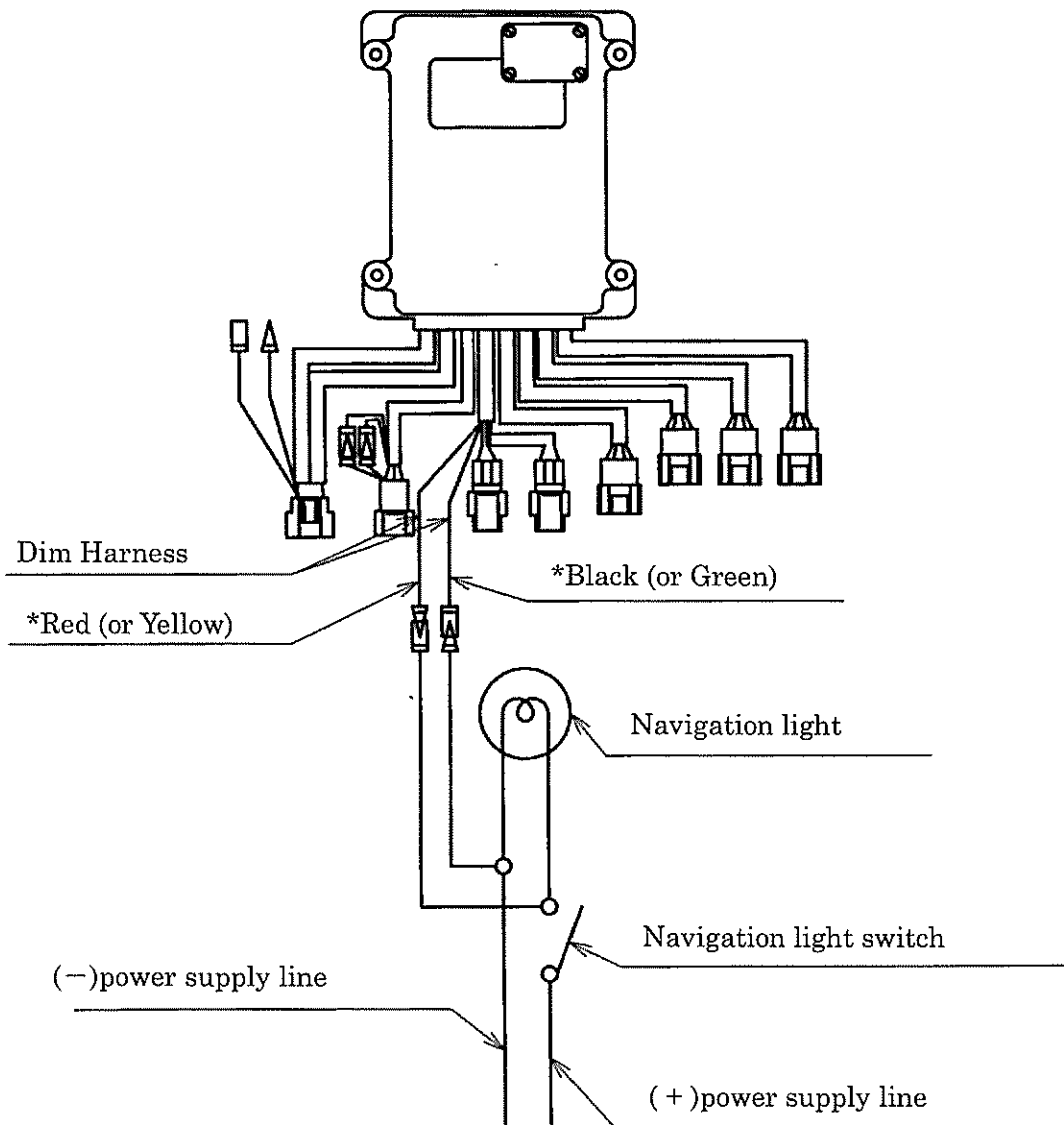

Note: Once dim harness is connected, brightness of the control head LED's illumination will be reduced whenever navigation light is ON.

OVERALL WIRING DIAGRAM

The diagram below shows a case with two engines operated from two control heads.

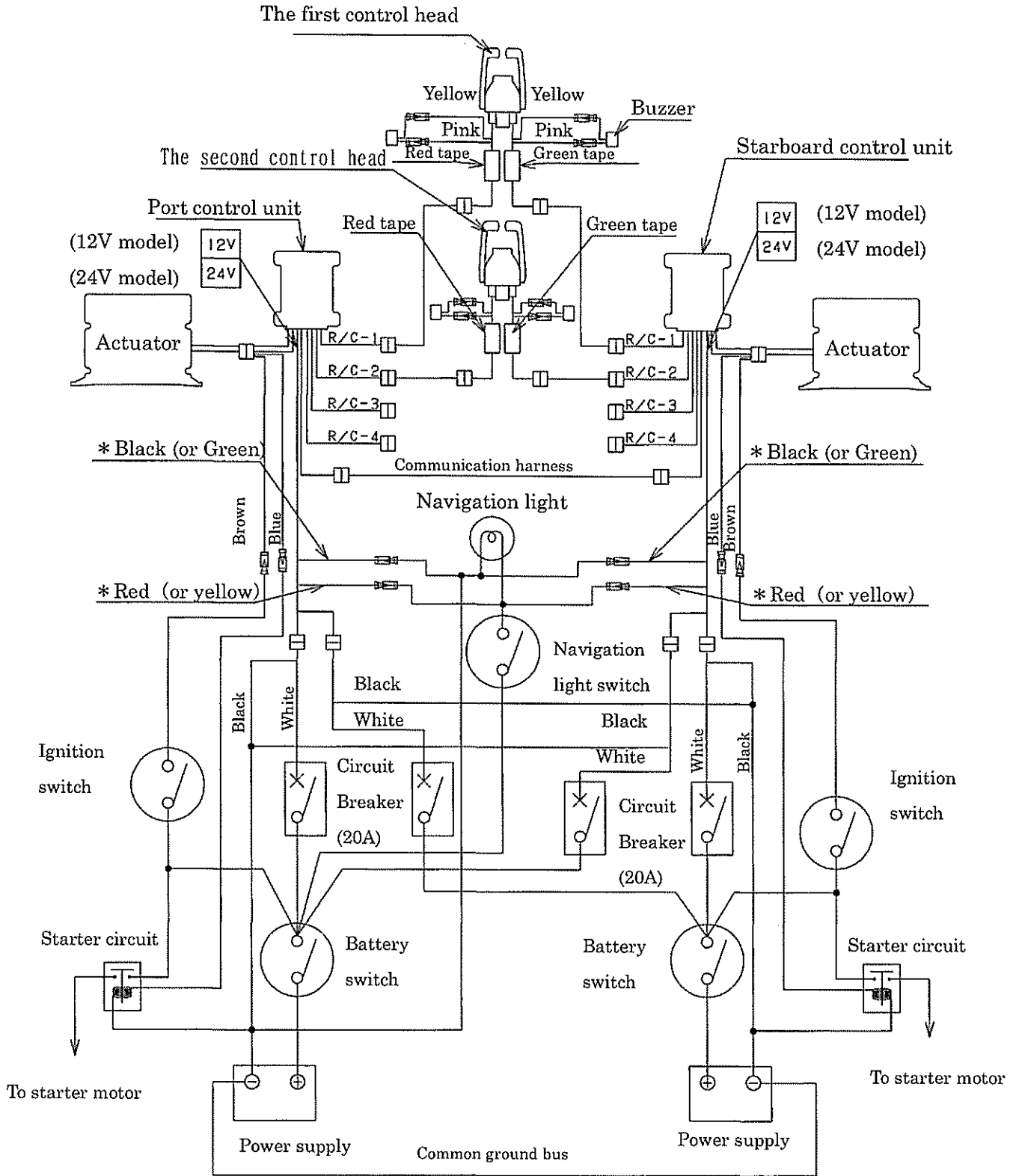

PUSH-PULL CABLE INSTALLATION

Instructions: → push-pull cables to actuator

1. Install the rod end to the rod and set with lock nut.
2. Tighten to 2.9 ~ 4.4 N · m (2.1 ~ 3.2 lbf · ft)
3. Remove the eight (8) actuator screws shown with arrows and remove the cover
4. Install the waterproof grommet around the cable.
5. Install the rod end, hub and waterproof grommet to the actuator mount groove as shown below.
6. Re-install the cover onto the actuator with screws.
7. Tighten to 1.2 ~ 1.8 N · m (0.9 ~ 1.3 lbf · ft)

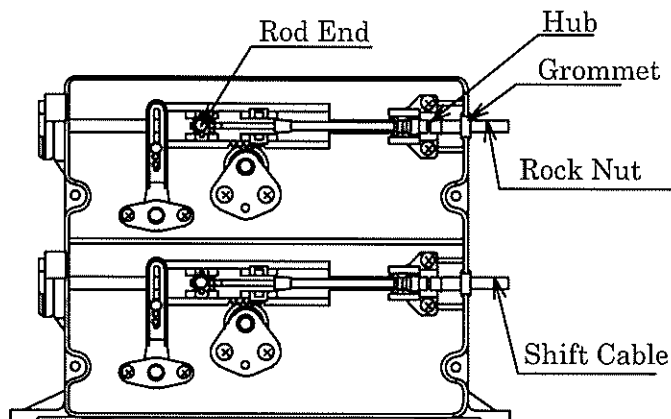
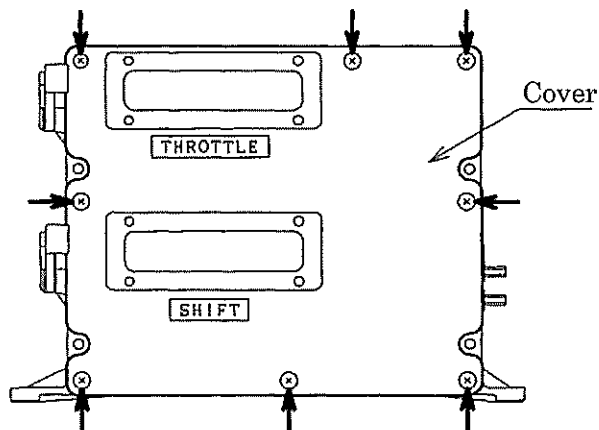
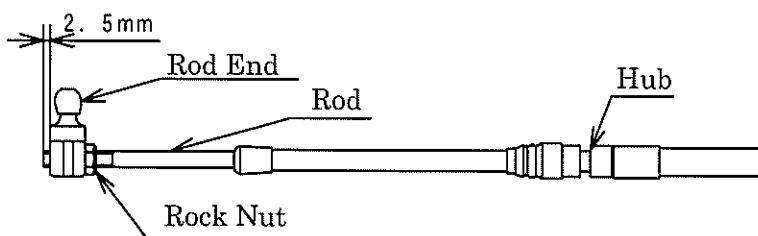

PUSH-PULL CABLE INSTALLATION

(continued)



CAUTION

1. Be sure to completely install the push-pull cables in the actuator before installing the other ends to the engine & gear.
2. Also turn OFF power supply to the control unit before installing the push-pull cables to the engine & gear.
3. Install the cables onto the engine as per the engine manual.
4. Please make sure that the system is installed such that the push-pull cable motions correspond properly with the engine and gearbox mode of operation (i.e. stroke direction and distance); otherwise damage could occur.

Instructions: → Initialization

8. Turn power ON to the KE system control unit.
9. Set the R/C-1 control head lever(s) to neutral position.
10. The throttle actuator should now be fully closed and the shift actuator should be in neutral position.
11. Positioning is completed once the neutral LED goes ON. Push-pull cables are now ready for installation to engine & marine gear as per engine manual.

ADJUSTING THE CONTROL UNIT

⚠ CAUTION

1. Be sure to turn OFF the power to the control unit before removing the push-pull cables from the engine / gear.
2. Once control unit adjustment is completed, re-install the cover for proper seal, torque to 1.0 ~ 1.7 N·m (0.7 ~ 1.2 lbf·ft). Then, carry out positioning of the actuator (see previous page).

Instructions: To adjust system settings compatibility with engine and gear, remove the control unit small cover (4 screws) and modify the DIP switch configurations, based on the tables below.

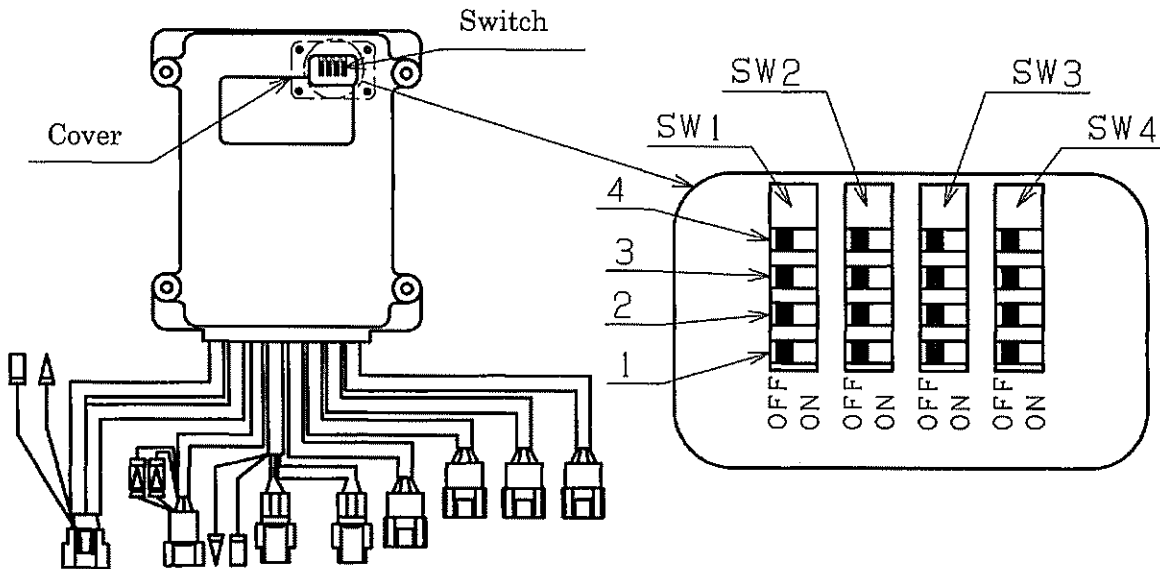

Switch functions

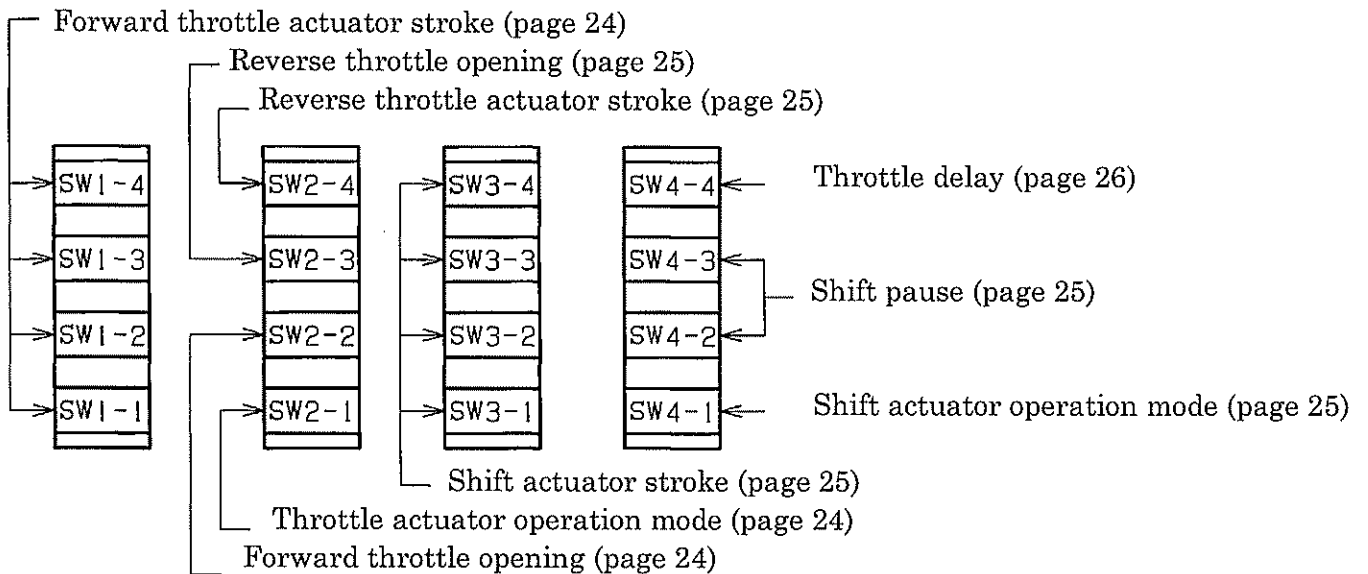

Throttle actuator mode

Select the following DIP switch configuration to set whether the engine speed is raised by pushing out the cable or by pulling in the cable. (Confirm on the engine side)

SW2-1	FUNCTION
OFF	Pull to open Throttle
ON	Push to open Throttle

※Before shipment, the switch is set to OFF(PULL TO OPEN THROTTLE).

Forward throttle stroke

Select the following DIP switch configurations for the desired throttle stroke settings. When the hand lever is operated from forward to full forward, the throttle actuator stroke can be set from 31mm to 73mm via 3mm intervals, plus a 80mm setting.

SW1-1	SW1-2	SW1-3	SW1-4	STROKE
ON	OFF	ON	ON	31mm
ON	OFF	OFF	ON	34mm
ON	OFF	ON	OFF	37mm
ON	OFF	OFF	OFF	40mm
OFF	ON	ON	ON	43mm
OFF	ON	OFF	ON	46mm
OFF	ON	ON	OFF	49mm
OFF	ON	OFF	OFF	52mm
OFF	OFF	ON	ON	55mm
OFF	OFF	OFF	ON	58mm
OFF	OFF	ON	OFF	61mm
OFF	OFF	OFF	OFF	64mm
ON	ON	ON	ON	67mm
ON	ON	OFF	ON	70mm
ON	ON	ON	OFF	73mm
ON	ON	OFF	OFF	80mm

※Before shipment, all the switches are set to OFF(64mm stroke).

Forward throttle opening

Select the following DIP switch configurations for the desired forward throttle opening curve. This function facilitates fine throttle adjustment over the idle to low RPM range and can be used to decrease the shock effect if the hand lever is operated suddenly.

SW2-2	FUNCTION
OFF	Forward throttle opening 1
ON	Forward throttle opening 2

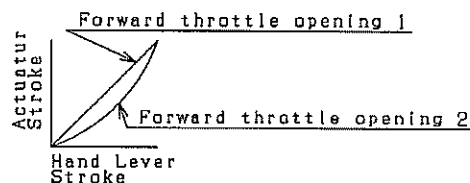

※Before shipment, the switch is set to OFF(Opening 1).

Reverse throttle opening

Select the following DIP switch configurations for the desired reverse throttle opening curve.

SW2-3	FUNCTION
OFF	Reverse throttle opening 1
ON	Reverse throttle opening 2

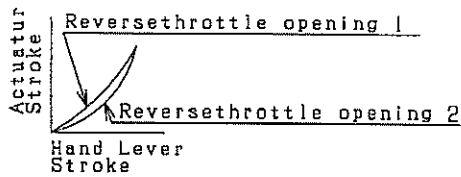

※Before shipment, the switch is set to OFF(Opening 1).

Reverse throttle stroke

Select the following DIP switch configurations for the desired reverse throttle setting.

SW2-4	FUNCTION
OFF	60% of the forward full open stroke
ON	80% of the forward full open stroke

※Before shipment, the switch is set to OFF(60% of the forward full open stroke).

Shift actuator mode

Select the following DIP switch configurations to set whether the clutch is shifted to the forward position by pushing out the cable or by pulling in the cable. (Confirm on the clutch side).

SW4-1	FUNCTION
OFF	Pull to go Forward
ON	Push to go Forward

※Before shipment, the switch is set to OFF(PULL TO GO FORWARD).

Shift stroke: Forward

Select the following DIP switch configurations for the desired forward shift stroke setting.

SW3-1	SW3-2	STROKE
ON	OFF	26mm
OFF	ON	30mm
OFF	OFF	34mm
ON	ON	40mm

※ Before shipment, both the switches are set to OFF(34mm stroke).

Shift stroke: Reverse

Select the following DIP switch configurations for the desired reverse shift stroke setting.

SW3-3	SW3-4	STROKE
ON	OFF	26mm
OFF	ON	30mm
OFF	OFF	34mm
ON	ON	40mm

※Before shipment, both the switches are set to OFF(34mm stroke).

Throttle delay

Select the following DIP switch configurations for the desired throttle delay setting. This function delays (~ 1-2 secs) the shock effect if the hand lever is operated suddenly from neutral to throttle.

SW4-4	FUNCTION
OFF	No throttle delay
ON	Throttle delay

※Before shipment, the switch is set to OFF(no throttle delay).

Shift pause

Select the following DIP switch configurations for the desired shift pause setting. This function delays the shock effect if the hand lever is operated suddenly from throttle to neutral.

SW4-2	SW4-3	FUNCTION
OFF	OFF	No shift pause
ON	OFF	2 seconds
OFF	ON	4 seconds
ON	ON	6 seconds

※Before shipment, both the switches are set to OFF(no shift pause).

OPERATION CHECK

Carry out operation check as follows once installation is completed.

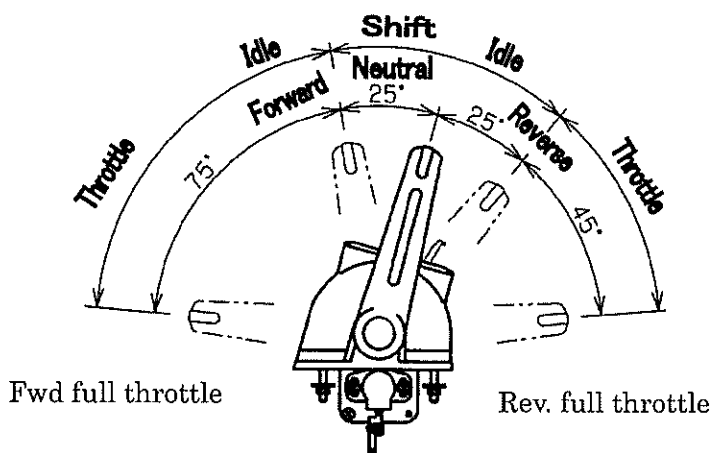

CAUTION

1. Never operate the hand lever while the engine is not running; otherwise, the actuator, push-pull cable, or engine / marine gear may be damaged.
2. Please make sure that the system is installed such that the push-pull cable motions correspond properly with the engine and gearbox mode of operation (i.e. stroke direction and distance); otherwise damage could occur.

Shift and throttle operation check

Step	Hand lever operation	Description (engine side)
1	Neutral → Forward	Shift actuator from neutral to forward
2	Forward → Forward full open	Throttle actuator from fully closed to full open
3	Forward full open → Neutral	Throttle actuator shifted from full open to fully closed Shift actuator shifted from forward to neutral
4	Neutral → Reverse	Shift actuator from neutral to reverse
5	Reverse → Reverse full open	Throttle actuator from fully closed to full open
6	Reverse full open → Neutral	Throttle actuator from full open to fully closed Shift arm shifted from reverse to neutral

If the correct operation cannot be made, change the operation mode. (See "Adjusting the Control Unit").

When the forward/neutral/reverse LED's flash, refer to "Alarm Codes".

Confirmation of the engine start

Step	Description	OK	Countermeasure if NG
1	Set the hand lever to NEUTRAL and start the engine	Engine starts.	Shorten the SIGP harness. (See page 16)
2	Shift the hand lever to FORWARD and start the engine.	Engine does not start.	Connect the SIGP harness. (See page 16)

MANUAL OPERATION METHOD (OPTION)

WARNING

Attempt manual operation only in cases of emergency (i.e. electrical system failure). Use for immediate return to shore

Instructions:

1. Install the mechanical control head and push-pull cable according to the instruction manual of the optional mechanical control head.
2. Install ball joint socket to the output end of the push-pull cable and fix it to the actuator.
3. Remove the black cover and expose the ball stud.
4. Tilt the selector knob fully in the arrow direction.
5. Remove the cable from the position and install its ball joint socket onto the ball stud and the hub onto the clamp.
6. The actuator can then be operated manually via the mechanical control head levers.
7. Return the selector knob to the original position after manual operation is no longer necessary.

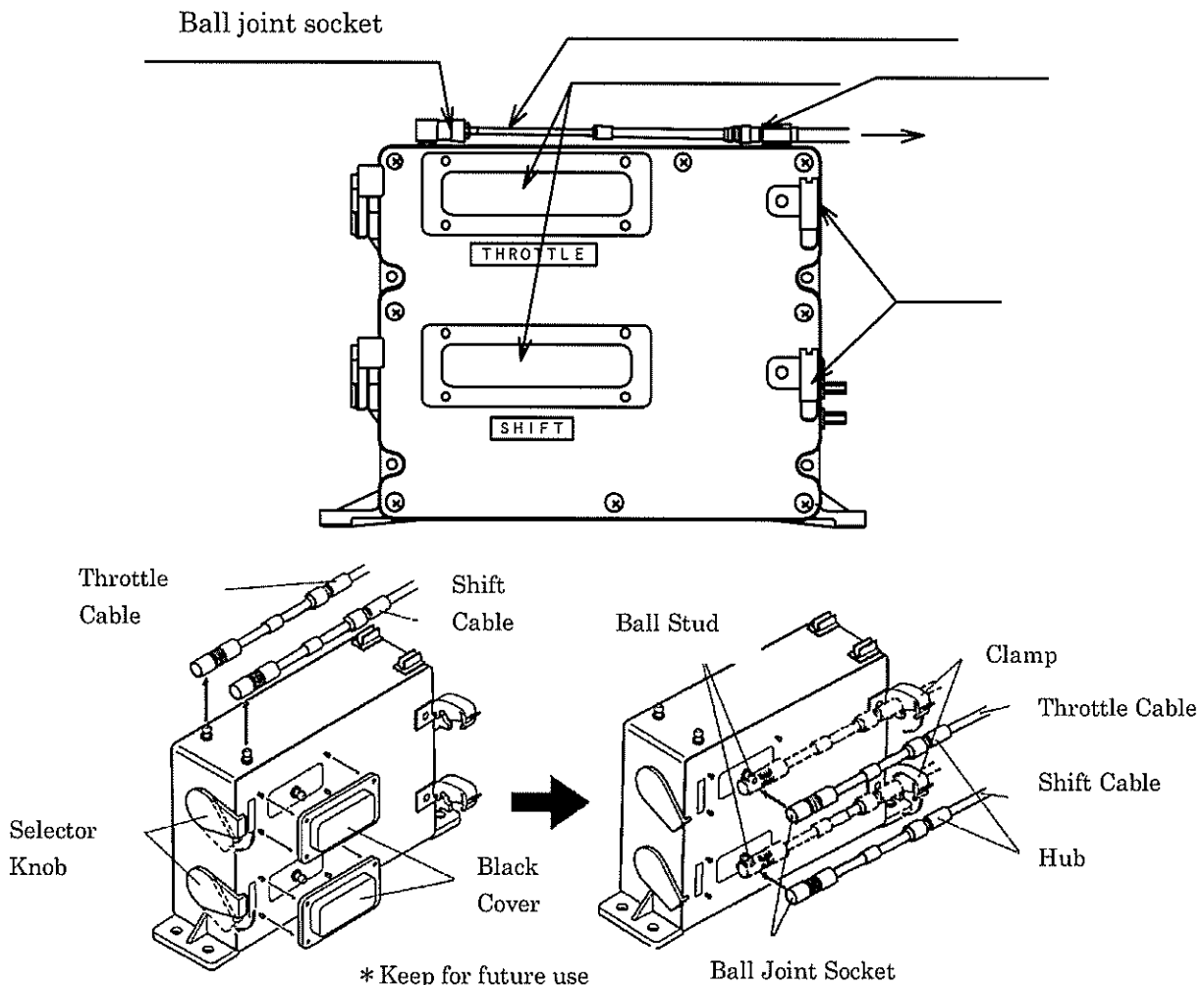

ALARM CODES

In case of a system operation fault, the failure code is indicated via the forward/neutral/reverse LED's flashing frequency and an optional buzzer.

LED Flash Frequency	Possible Cause	Check / Countermeasure	Reference
1 * Shift Actuator Signal	(1)Shift actuator and control unit are not connected correctly. (2)Shift actuator set to the manual operation. (3)Shift actuator harness wire damaged or shorted. (4)Harness actuator wire damaged or shorted. (5)12-pole coupler harness of the control unit wire damaged or shorted.	(1)Reconnect the shift actuator and control unit. (2)Set the actuator to NEUTRAL and set the selector knob to "Electronic Operation". (3)Consult your dealer. (4)Replace the harness actuator. (5)Consult your dealer.	page 15 page 28 _____ page 15 _____
2 ** Throttle Actuator Signal	(1)Throttle actuator and control unit are not connected correctly. (2)Throttle actuator set to the manual operation. (3)Throttle actuator harness wire damaged or shorted. (4)Harness actuator wire damaged or shorted. (5)12-pole coupler harness of the control unit wire damaged or shorted.	(1)Reconnect the throttle actuator and control unit. (2)Set the actuator to a middle point and set the selector knob to "Electronic Operation". (3)Consult your dealer. (4)Replace the harness actuator. (5)Consult your dealer.	page 15 page 28 _____ page 15 _____
3 *** Control Head	(1)Control head not connected to R/C-1 of control unit (2)Control head and control unit not connected correctly. (3)Three-pole coupler of control head disconnected. (4)Control head harness wire damaged or shorted. (5)Harness remote control wire damaged or shorted. (6)R/C-1,2,3,and 4 harnesses of control unit wire damaged or shorted.	(1)Connect the control head to R/C-1. (2)Reconnect the control head and control unit. (3)Connect the three-pole coupler. (4)Consult your dealer. (5)Replace the harness remote control. (6)Consult your dealer.	page 14 page 14 page 14 _____ page 14 _____

ALARM CODES (continued)

LED Flash Frequency	Possible Cause	Check / Countermeasure	Reference
4 **** Shift Actuator	<p>(1) Push-pull cable installed without positioning of the shift actuator.</p> <p>(2) Shift actuator stroke exceeding the stroke of clutch.</p> <p>(3) Shift actuator set to the manual operation.</p> <p>(4) Loose cable end of the shift actuator.</p> <p>(5) Loose nut of the clutch connection.</p> <p>(6) Shift actuator harness wire damaged or shorted.</p> <p>(7) Harness actuator wire damaged or shorted.</p> <p>(8) 12-pole coupler harness of control unit wire damaged or shorted.</p> <p>(9) Heavy clutch load, resulting in failure of smooth shift actuator operation.</p>	<p>(1) Perform proper cable positioning & initialization of actuator.</p> <p>(2) Reduce the stroke of shift actuator.</p> <p>(3) Set the actuator to the neutral position and set the knob to "Electronic Operation".</p> <p>(4) Fix the cable end.</p> <p>(5) Retighten the clutch connection nut.</p> <p>(6) Consult your dealer.</p> <p>(7) Replace the harness actuator.</p> <p>(8) Consult your dealer.</p> <p>(9) Reduce the clutch side load.</p>	<p>page 22</p> <p>page 23</p> <p>page 28</p> <p>page 21</p> <p>page 22</p> <p>page 15</p> <p>page 15</p>
5 ***** Throttle Actuator	<p>(1) Push-pull cable installed without positioning of the shift actuator.</p> <p>(2) Cable not correctly installed to the throttle actuator.</p> <p>(3) Throttle actuator set to the manual operation.</p> <p>(4) Loose cable end of the throttle actuator.</p> <p>(5) Loose nut of the engine connection.</p> <p>(6) Throttle actuator harness wire damaged or shorted.</p> <p>(7) Harness actuator wire damaged or shorted.</p> <p>(8) 12-pole coupler harness of control unit with damaged or shorted.</p>	<p>(1) Perform proper cable positioning & initialization of actuator.</p> <p>(2) Install the cable correctly.</p> <p>(3) Set the actuator to the middle point and set the knob to "Electronic Operation".</p> <p>(4) Fix the cable end.</p> <p>(5) Retighten the engine connection nut.</p> <p>(6) Consult your dealer.</p> <p>(7) Replace the harness actuator.</p> <p>(8) Consult your dealer.</p>	<p>page 22</p> <p>page 21</p> <p>page 28</p> <p>page 21</p> <p>page 22</p> <p>page 15</p> <p>page 15</p>

ALARM CODES (continued)

LED Flash Frequency	Possible Cause	Check / Countermeasure	Reference
6 ***** * Power	(1)One of duplex power lines is disconnected. (2)Either circuit breaker is OFF. (3)Harness power supply coupler not connected correctly. (4)Battery voltage beyond the operating voltage range. (5)Harness power supply wire damaged or shorted. (6)24 or 12V harness of the control unit broken.	(1)Connect both lines (2)Turn ON both breakers. (3)Reconnect the coupler of harness power supply. (4)Adjust voltage to be within the operating voltage range. (5)Replace the harness power supply. (6)Consult your dealer.	page 17 page 17 page 17 page 2 page 17
7 ***** ** Control Head	(1)Selector switch kept pressed. (2)Control head harness shorted. (3)Harness remote control shorted. (4)R/C-1,2,3,and 4 harnesses of control unit with shorting.	(1)Reset the selector switch in a free state. (2)Consult your dealer. (3)Replace the harness remote control. (4)Consult your dealer.	page 6 page 14
8 ***** *** COM	(1)Communication harness with wire breakage or shorting. (2)One of the control units has no power.	(1)Replace the communication harness. (2)Turn ON circuit breaker.	page 18
9 ***** **** TROLL	COM/POWER harness damaged or shorted, affecting trolling operation	Replace the COM/POWER harness; verify trolling operation	Trolling Manual

TROUBLESHOOTING

Consult this table if problems occur without an associated flashing LED alarm code.

Symptom	Possible Cause	Check / Countermeasure
No operation even when power supply is ON.	(1)Harness power not connected correctly. (2)Circuit breaker OFF.	(1)Connect the harness power correctly.(See page 17) (2)Turn ON circuit breaker.
No LED's ON	(1)Control head hand lever not in neutral during initial operation. (2)R/C-1 of the control unit not connected with the control head.	(1)Set the hand lever to NEUTRAL with power ON.(See Page 8) (2)Connect the control head to R/C-1.(See page 14)
F or N or R LED does not light ON	(1)Wire damage in control head harness. (2)Wire damage in harness remote control. (3)LED failure.	(1)Consult your dealer. (2)Replace the harness remote control.(See page 14) (3)Consult your dealer.
F, N, R LED lights ON but shift clutch does not engage.	(1)Push- Cable of shift actuator damaged.	(1)Replace the cable.(See page 21)
F, N, R LED lights ON but engine speed does not respond.	(1)Throttle actuator cable damaged	(1)Replace the cable.(See page 21)
Engine does not start.	(1)Low battery voltage. (2)SIGP harness extension wire too long.	(1)Charge the battery. (2)Shorten the SIGP harness extension wire. (See page 16)
Neutral throttle operation not functional.	(1)Neutral throttle operation is not set correctly. (2)Faulty selector switch.	(1)Carry out setting correctly. (See page 8) (2)Consult your dealer.

MAINTENANCE AND SERVICE

Control head & Control unit

1. Wash with water and dry to prevent corrosion.
2. Do not apply grease because this assembly contains electronic components.

Shift & Throttle Actuators

1. Wash with water and dry to prevent corrosion.
2. Apply marine grease to exposed fasteners & moving parts.
3. Check fasteners for looseness periodically.

Harnesses

1. Check all harnesses for wiring damage periodically.
2. Check all connectors for proper seating periodically.

Push-pull cables

1. Check push-pull cable connections at both ends (actuator end, engine end) for looseness periodically.
2. Also check push-pull cables for damage, wear, and corrosion periodically.
3. Check for smooth push-pull cable motion while operating levers in each position: Rmax, R, N, F, Fmax; look for signs of backlash or obstructed motion. Verify that there is no alarm code displayed on the control head panel.
4. In the case of a ball joint type connection to engine lever, carefully inspect abrasion and apply lubricant grease regularly.

Note: Repair or replace any damaged part; consult with dealer.

CONTROL HEAD TEMPLATE

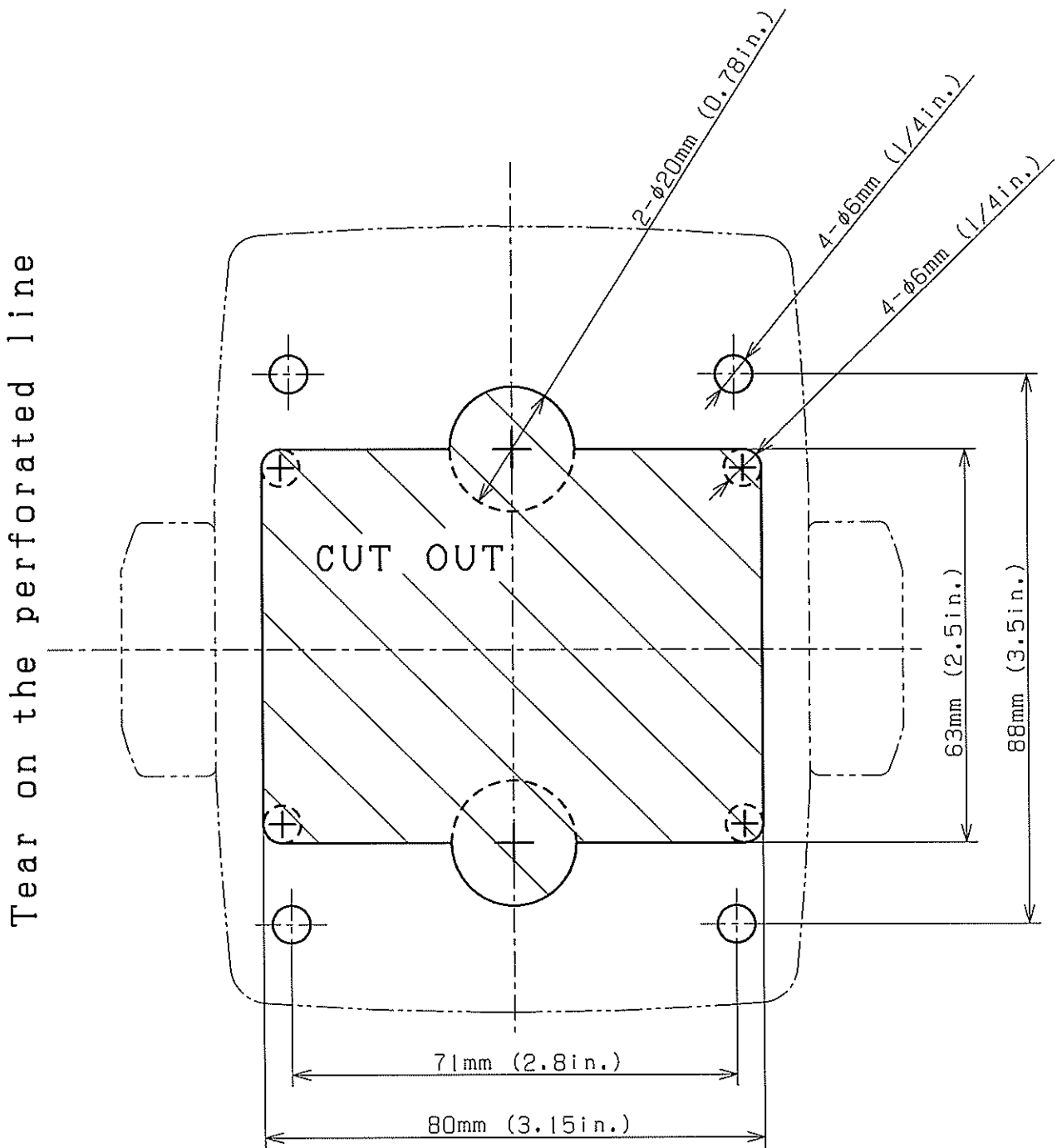

CONTROL UNIT TEMPLATE

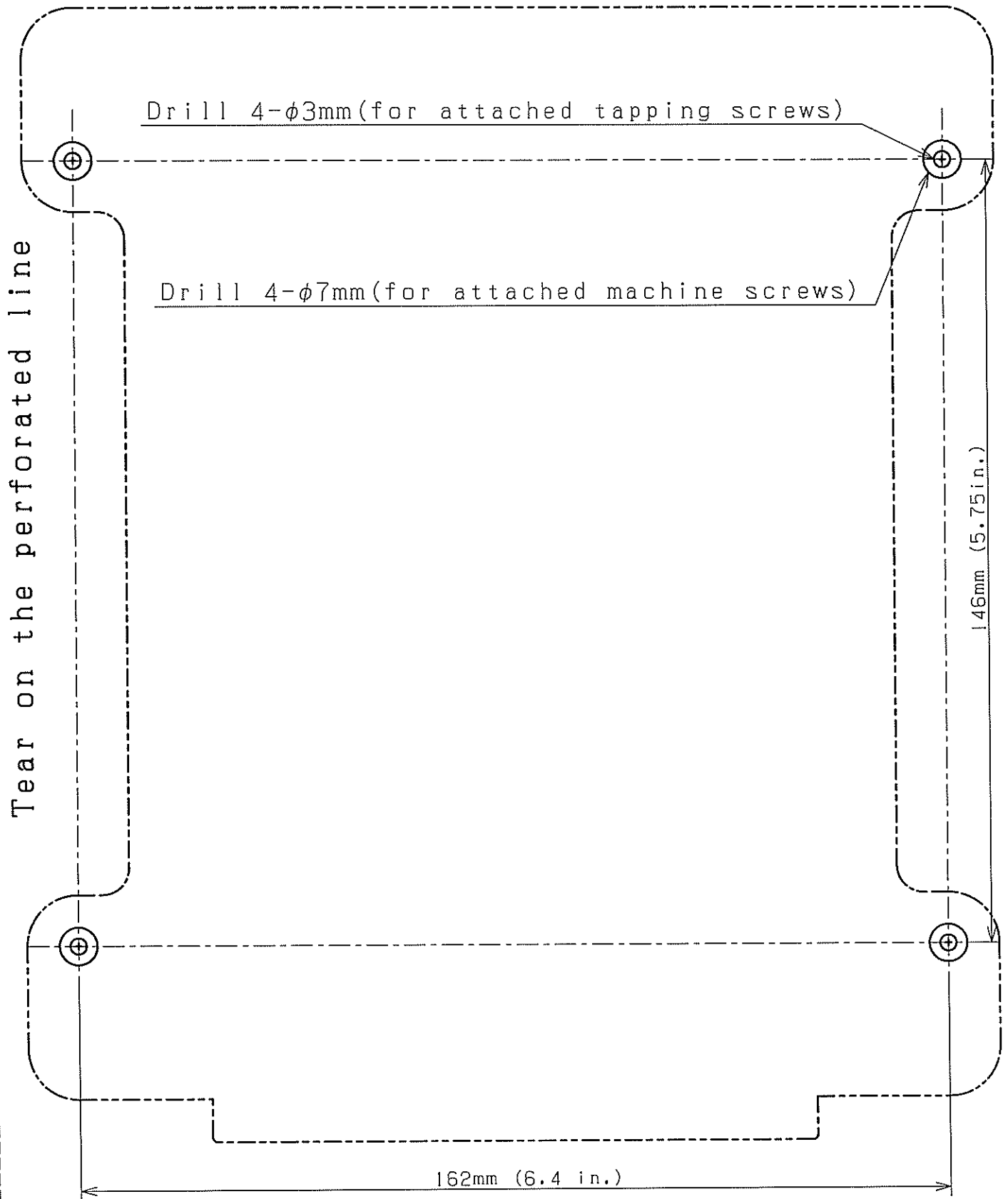

NHK MEC Corporation

**3-21-10, SHIN-YOKOHAMA, KOHOKU-KU, YOKOHAMA,
222-0033, JAPAN**

PHONE:+81(45)475-8902 FAX:+81(45)475-8907

M000078 5F 11.03. PRINTED IN JAPAN COPYRIGHT 2011