

AT A GLANCE

FEATURES

- Patented NFB (No FeedBack™) helm
- Precise feel of 4 turns from lock-to-lock.
- Minimal clutch free play.
- Standard 3/4" round tapered steering wheel shaft.
- Stainless steel cable output ends.
- Fast, easy installation.
- Kits include: cable, helm, 90° bezel and hardware.
- Meets A.B.Y.C. standards.
- Meets N.M.M.A. certification requirements.



NFB™ RACK SINGLE CABLE SYSTEM
(Steering Wheel not included.)

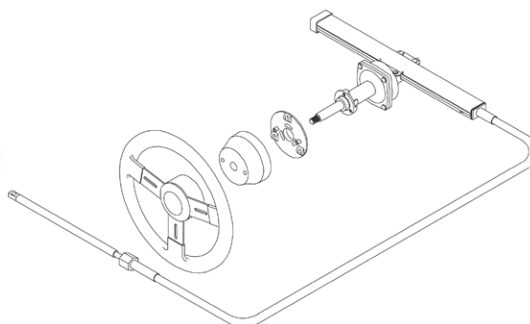

NFB™ MECHANICAL RACK STEERING (SINGLE) SYSTEM

The easy-to-sell, easy-to-install upgrade to the most popular Rack and Pinion steering system in boating. Teleflex has applied its patented No FeedBack technology to the incredible precision of a rack and pinion system, and engineered-in serious advances in steering comfort and control. And — it's a drop-in replacement for Teleflex "The Rack".

APPLICATIONS

NFB Rack single-cable systems are suitable for most single-station boats with a single non-power-assisted outboard engine up to V-6 and minimal engine flutter or steering instability. NFB Rack accepts wheels up to 16" diameter. New Back Mount design means easy installation; helm & cable are installed as a unit from behind dash and replace standard Teleflex rack steering without dash modifications.

COMPLETE SYSTEMS	
NFB Rack Steering Kit (Single Cable)	SS151XX
COMPONENTS	
NFB Rack Helm (single/dual)	SH5230P
Rack Single Cable	SSC134XX
Rack NFB Bezel (90°)	SB39544P
OPTIONS	
NFB Rack Tilt Dash Module (single/dual) Each Kit Includes Tilt Helm & Tilt Mechanism	SHT91630
NFB Rack Tilt Helm (single/dual)	SH91630P*
Sport Tilt Mechanism	SH91800P
Sport Plus Tilt Mechanism	SH91900P
Dash Wedge Kit (10°)	SB27448P
Dash Wedge Kit (20°)	SB27449P
TFXtreme Rack Single Cable	SSC154XX
Cable Gard (fits most tilt tubes)	SA39329P
Steering Wheel Hardware Kit (Old #2745417P)	SA27454P

* Requires Tilt mechanism to complete tilt steering system installation

