

AT A GLANCE

FEATURES

- Patented NFB (No FeedBack™) helm
- Twin cable system for maximum control.
- Comfortable 4.2 turns from lock-to-lock
- Standard 3/4" tapered steering wheel shaft
- Stainless steel cable output ends.
- Fast, easy installation: uses Teleflex Quick Connect (QC) steering cables.
- Kits include: cable, helm, 90° bezel and hardware.
- Meets A.B.Y.C. standards.
- Meets N.M.M.A. certification requirements.

FEATURES

SS148 Kits are sold in lengths from 12 – 16 feet. All other lengths will require the purchase of individual components.



NFB™ 4.2 DUAL CABLE SYSTEM
(Steering Wheel not included.)

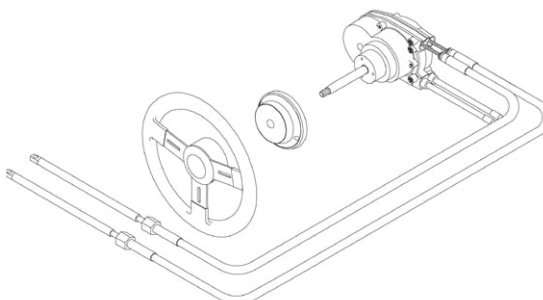

NFB™ 4.2 MECHANICAL ROTARY STEERING (DUAL) SYSTEM

Patented No FeedBack Steering Control for about the cost of an old-fashioned steering replacement. With the advantage of 4.2 turns lock-to-lock and our patented No FeedBack steering to lock out steering loads, Teleflex's 4.2 Rotary NFB Steering is the ideal system for most non-power-steered boats. This rugged dual cable system is made for applications with engine flutter or steering instability. The helm is a drop-in replacement for current generation Safe-T with no dash modifications required.

APPLICATIONS

NFB 4.2 dual-cable systems are suitable for most single-station boats with a single non-power-assisted outboard or stern drive engines up to V-6 in which engine flutter or steering instability is present. 4.2 accepts wheels up to 16" diameter. Replaces nearly all Teleflex Safe-T® steering systems without dash modification. Replaces nearly all Teleflex Safe-T® steering systems (including twin cable) without dash modification.

COMPLETE SYSTEMS	
NFB 4.2 Dual Steering Kit (Dual Cable)	SS148XX
COMPONENTS	
NFB 4.2 Dual Helm	SH4920P
(2) QC Cables	SSC62XX
Rotary NFB Bezel (90°)	SB27150P
OPTIONS	
NFB 4.2 Dual Tilt Helm	SH91527P*
Sport Tilt Mechanism	SH91800P
Sport Plus Tilt Mechanism	SH91900P
Bezel (20°)	SB27483P
Cable Gard (fits most tilt tubes)	SA39329P
SERVICE ITEMS	
QC II Cable (for most Teleflex rotary) (Includes SA27620P Helm Converter)	SSC61XX
Steering Wheel Hardware Kit (Old #2745417P)	SA27454P
Spent Travel Tube (Rotary NFB)	SA38603P

* Requires Tilt mechanism to complete tilt steering system installation

