

AT A GLANCE

FEATURES

- Fits all popular out-boards, inboards and stern drives
- Emergency cut-off feature available
- Ergonomically designed handgrip for maximum comfort and convenience
- Crisp, positive detents
- Built in friction drag to reduce throttle creep
- Neutral interlock feature to prevent accidental shifting
- New non-corrosive cover/housing
- Standard control suits 33C type cables
- Neutral safety switches available for many MV3 models
- Standard control suits 33C type cables
- Neutral throttle warm-up

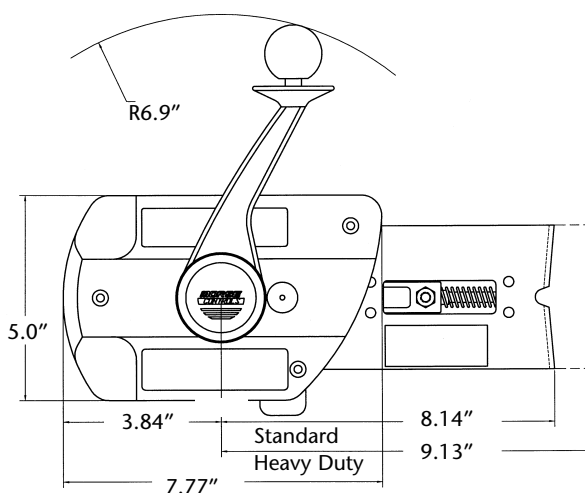

MV3 SKI BOAT/JET BOAT CONTROL

TECHNICAL DATA

The MV3 dual function, single lever control is the choice of competitive ski boat drivers and jet boat enthusiasts. Suits 33C type control cables. Models available for Berkeley Jet and Mercury 175hp Sport Jet with 43 series cables.

ENGINE CONTROLS	PART NUMBER
MV-3 Standard For Outboard, Stern Drive Or Inboard	
MV-3 Standard Control RH Orientation, AFT Cable Entry, Neutral Safety Switch (Old No. 311364)	CH2920P
MV-3 Competition Ski Boat	
MV-3 Competition Ski Boat, RH Orientation, Forward Cable Entry (Old No. 311335)	CH2900P
MV-3 Competition Ski Boat with I/O Cut-Off Switch. (Old No. 311335-001)	CH2910P
MV-3 Right Hand Mount, Immersion Proof Switch, Warm Up Limiter (Old No. 311480).	CH2930P
MV-3 For Jet Berkeley:	
MV-3 Jet Control (Berkeley), RH Orientation, Aft Cable Entry (Old No. 311412)	CH2940P
MV-3 Jet Control (Berkeley), LH Orientation, Forward Cable Entry (Old No. 311413)	CH2945P
Mercury Sport Jet 175 (uses special 4300 cable for reverse gate):	
MV-3 HD Control (Merc 175) ion, Aft Cable Entry, Immersible Neutral Safety Switch, Throttle Limiter (Old No. 311508)	CH2950P

OPTIONS/SERVICE ITEMS	PART NUMBER
Ball Knob, Black	4009819
Neutral Safety Switch Replacement	300928
Immersible Neutral Safety Switch for Jet	051801-031
MV-3 Emergency Cut-Off Switch Kit for Jet and Outboard	311482-002
MV-3 Emergency Cut-Off Switch Kit for I/O and Inboard	311482-001

NOTES: Check with Engine/Drive Manufacturer for details particular to your power train.



OPTIONS/SERVICE ITEMS	PART NO.
Ball Knob, Black	4009819
MV-2 Hand Lever Assembly	311354
Neutral Safety Switch Replacement	300928
OMC Replacement Shift Switch Only	301585
Immersible Neutral Safety Switch for Jet	051801-031
MV-3 Emergency Cut-Off Switch Kit for Jet and Outboard	311482-002
MV-3 Emergency Cut-Off Switch Kit for I/O and Inboard	311482-001

COMPATIBLE CABLES	PART NO.
OEM/Univ. 3300 Types	
Mercury 3600 type cable (premium)	CCX630
Universal 3300 Types	
3300 cable (standard)	CC172XX/CC230XX
3300 cable (midrange)	CC332XX
TFXTREME 3300 cable (premium)	CCX633XX
Jet Gate Control Cables:	
Sport Jet 90 & early 120	CC213XX
(This is a special 33 type cable with different configuration at drive end for 90 and early 120's.)	
Sport Jet 175	CC400XX
(This is a special 43 type cable with different configuration at drive end for 175's.)	
Purchase of cable connection Kits (may be required to complete control system installation)	

XX = length in feet

