

KE-5

ELECTRONIC CONTROL SYSTEM

INSTRUCTIONAL MANUAL

Table of Contents

INTRODUCTION -----	1
BASIC PERFORMANCE -----	2
NAME OF EACH PART -----	4
COMPONENTS -----	5
NAME AND FUNCTION OF CONTROL UNIT COMPONENTS --	6
NAME AND FUNCTION OF CONTROL HEAD COMPONENTS --	7
HOW TO OPERATE -----	8
Initial operation after power " ON " -----	8
Shift & Throttle operation -----	8
Neutral throttle operation -----	9
Station transfer for 2, 3, 4 and 5 station operation from a neutral position -----	9
Station transfer for 2, 3, 4 and 5 station operation from a forward throttle position -	9
INSTALLING THE CONTROL HEAD -----	10
INSTALLING THE CONTROL UNIT -----	11
CONNECTING THE CONTROL HEAD AND CONTROL UNIT----	12
CONNECTING THE ENGINE AND CONTROL UNIT -----	13
CONNECTING THE HARNESS POWER SUPPLY -----	15
CONNECTING THE COMMUNICATION HARNESS -----	16
CONNECTING THE DIM HARNESS -----	17
OVERALL WIRING DIAGRAM -----	18
ADJUSTING THE CONTROL UNIT -----	19
1. Setting the type of throttle output -----	22
2. Setting the idle relay action -----	22
3. Setting the throttle opening -----	22
4. Setting the reverse throttle -----	23
5. Setting the throttle delay -----	23
6. Setting the shift pause -----	23
OPERATION CHECK -----	24
1. Shift and throttle operation check -----	24
ALARM INDICATION -----	25
CHECK POINTS IN CASE OF TROUBLE -----	26
MAINTENANCE AND SERVICE -----	27
CONTROL HEAD TEMPLATE -----	28
CONTROL UNIT TEMPLATE -----	29

INTRODUCTION

This manual has been prepared to ensure your correct installation and operation of the KE-5 system. Be sure to read through this manual to understand the content thoroughly with care to prevent injury or damage to the property through abuse. Always keep the manual within your reach during operation. This product controls the shift (gear) and throttle (governor). It is recommended therefore to read the manual of engine and gear.

The specifications may be subject to change without notice in view of improvement, resulting in more or less difference between the content of the manual and the product. In case of ambiguity or questions concerning the product or the manual, consult with your dealer.

SAFETY PRECAUTIONS

This manual contains precautions under the following headers, which, if not observed, may result in injury or damage to the property. Pay particular attention on these precautions.

WARNING

Failure to comply with a Warning may result in an accident of death or heavy injury.

CAUTION

Failure to comply with a Caution may result in an accident of light injury or damage to the product or properties.

CAUTION

This system does not provide a device for shift in gear protection,
i. e. neutral safety switch.

BASIC PERFORMANCE

1. Electric Performance

(1) Supply voltage

DC9V~31V

(2) Maximum current consumption: 1A or less

2. Output

(1) Type1 (Throttle : Current Output)

(a) Shift

Forward Switch (Normally Open)

Capacity : 24V, 2A max.

Reverse Switch (Normally Open)

Capacity : 24V, 2A max.

(b) Throttle

Current output : 4mA to 20mA

Idle Validation Switch (Normally Closed)

Capacity : 24V, 2A max.

(2) Type2 (Throttle : Voltage Output)

(a) Shift

Forward Switch (Normally Open)

Capacity : 24V, 2A max.

Reverse Switch (Normally Open)

Capacity : 24V, 2A max.

(b) Throttle

Voltage output: 0.2V to 4.5V

Idle Validation Switch (Normally Closed)

Capacity : 24V, 2A max.

(3) Type3 (Throttle : PWM Output)

(a) Shift

Forward Switch (Normally Open)

Capacity : 24V, 2A max.

Reverse Switch (Normally Open)

Capacity : 24V, 2A max.

(b) Throttle

PWM output : 8% to 92% Duty Cycle, 500Hz

Idle Validation Switch (Normally Closed)

Capacity : 24V, 2A max.

3. Temperature Range

(1) Operating temperature:-20~+75° C

(2) Storage temperature : -40~+100° C

Note:

For Type1 (Current Output)

Select the harness Shift/Throttle P/N NM0626-05.

(Refer to the page 4, item ⑤.)

Note:

For Type2 (Voltage Output)

Select the harness Shift/Throttle P/N NM0625-05.

(Refer to the page 4, item ⑤.)

Note:

For Type3 (PWM Output)

①Set the dip switch SW1-1, 2 and 3 "ON".

(Refer to the page 22.)

②Select the harness Shift/Throttle P/N NM0631-05.

(Refer to the page 4, item ⑤.)

4. Principal Functions

- (1) Shift :Forward/Reverse operation
- (2) Throttle: Acceleration/deceleration
- (3) Neutral throttle: Only the throttle is activated to warm up the engine.
- (4) Control Station: Up to 5 stations.
- (5) Dim display: Decreases illuminance of the lamp on the control head in the night time.
- (6) Fault indication: Detect system faults and indicate by the frequency of flashing of the pilot lamp of the control head.

NAME OF EACH PART

The figure below shows an example of two engines/
two control station system

☐ : Indicates identification

☐ ← : Indicates the destination of connection

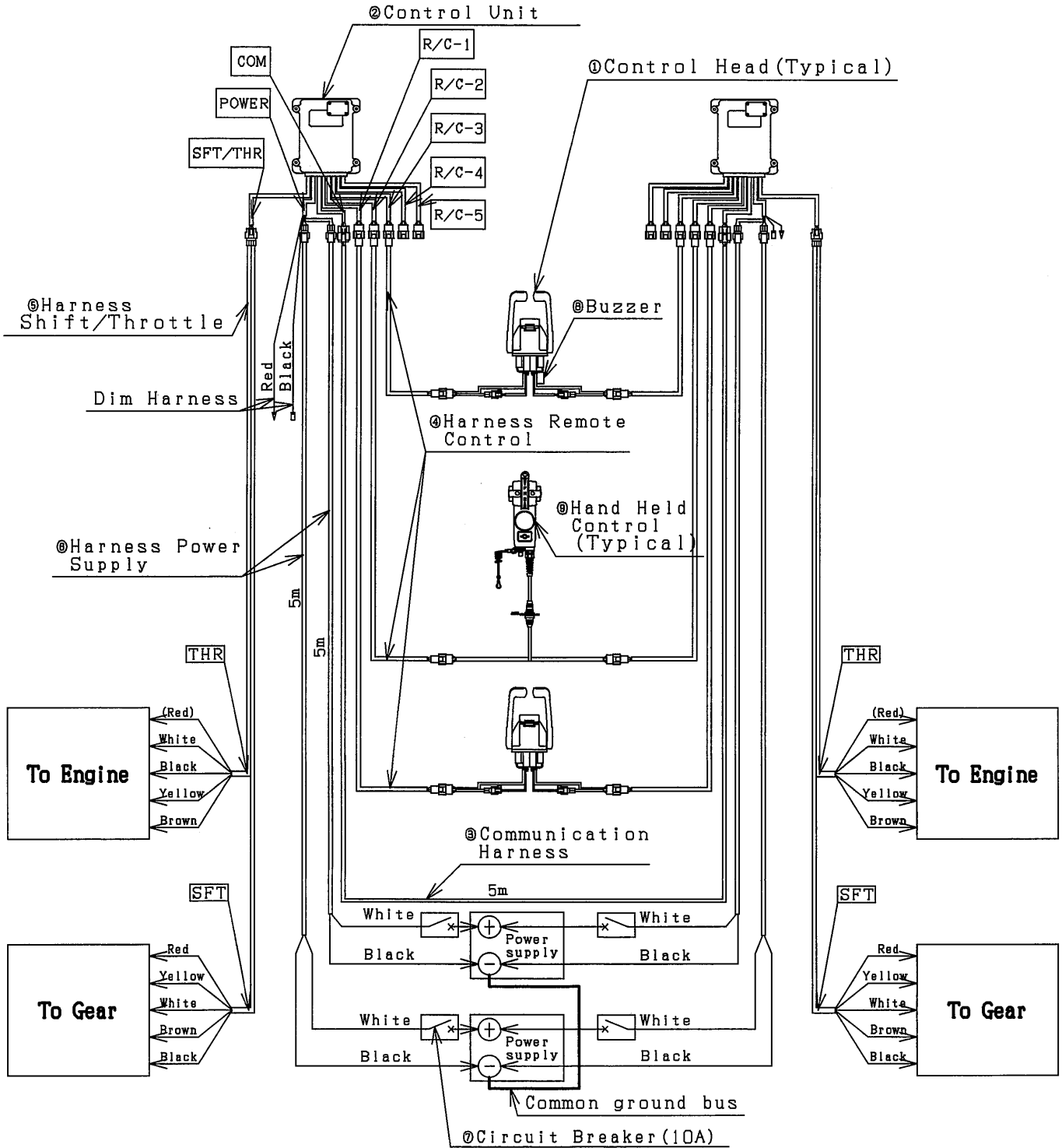

COMPONENTS

No.	Name		Part No.	Required										Note										
				Single engine					Two engines															
				1st	2nd	3rd	4th	5th	1st	2nd	3rd	4th	5th											
①	Control Head		NM0511-00	1	2	3	4	5	—	—	—	—	—											
			NM0510-00	—	—	—	—	—	1	2	3	4	5											
②	Control Unit		NM0492-00	1	1	1	1	1	2	2	2	2	2											
③	Communication Harness	5m	NM0619-05	—	—	—	—	—	1	1	1	1	1											
④	Harness Remote Control	4m	NM0616-04											For length other than those listed in the left, consult your dealer.										
		6m	NM0616-06																					
		8m	NM0616-08																					
		10m	NM0616-10																					
		12m	NM0616-12																					
		14m	NM0616-14																					
		16m	NM0616-16																					
		18m	NM0616-18																					
		20m	NM0616-20																					
		22m	NM0616-22												1	2	3	4	5	2	4	6	8	10
		24m	NM0616-24																					
		26m	NM0616-26																					
		28m	NM0616-28																					
		30m	NM0616-30																					
		32m	NM0616-32																					
34m	NM0616-34																							
36m	NM0616-36																							
38m	NM0616-38																							
40m	NM0616-40																							
50m	NM0616-50																							
⑤	Harness Shift/Throttle	Type1 5m	NM0626-05											for Current output										
		Type2 5m	NM0625-05											1	1	1	1	1	2	2	2	2	2	for Voltage output
		Type3 5m	NM0631-05																					for PWM output
⑥	Harness Power Supply		5m	NM0414-28																				
			10m	NM0414-33											2	2	2	2	2	4	4	4	4	4
⑦	Circuit Breaker	10A	NJ0595-00	2	2	2	2	2	4	4	4	4	4	Option.										
⑧	Buzzer		24V model	NJ0515-00										Option.										
			12V model	NJ0251-00											1	2	3	4	5	2	4	6	8	10
⑨	Hand Held Control		You can use the Hand Held Control in place of the Control Head (①). Consult your dealer for details.										Option.											

Note: Select ⑤Harness Shift/Throttle depend on the type of throttle output referring the charts on page 2, item 2 "Output".

NAME AND FUNCTION OF CONTROL UNIT COMPONENTS

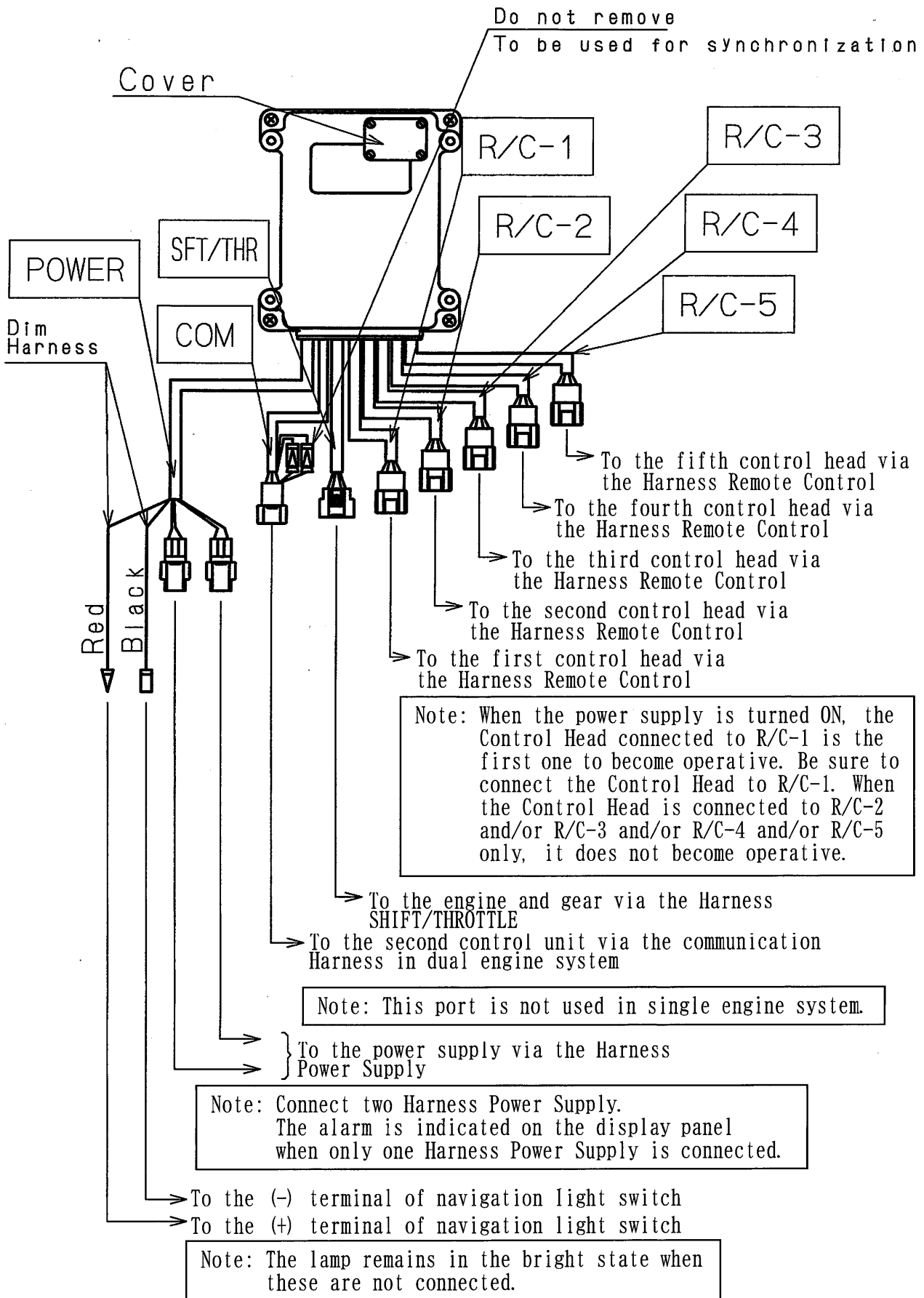

NAME AND FUNCTION OF CONTROL HEAD COMPONENTS

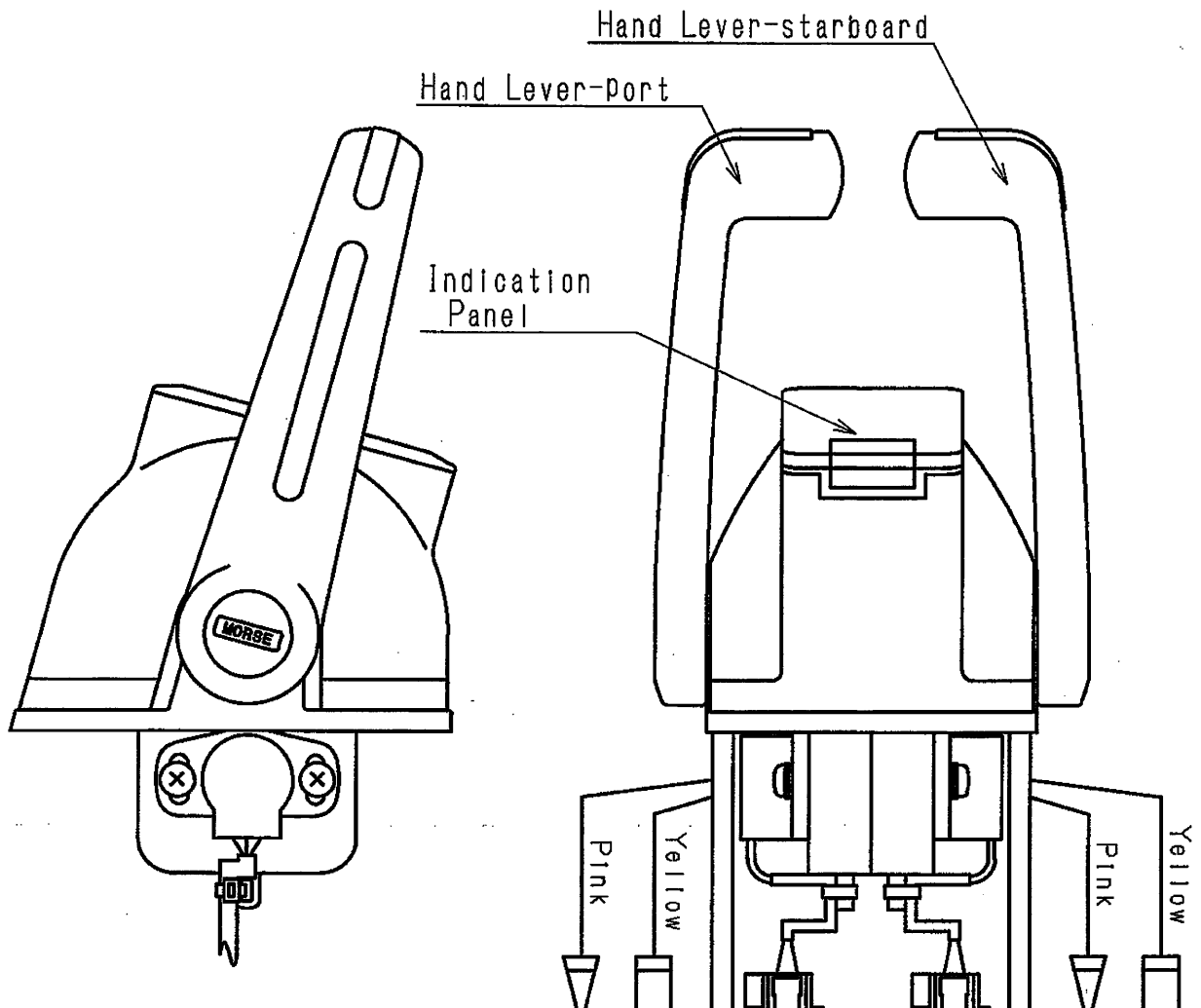

(1) Indication Panel

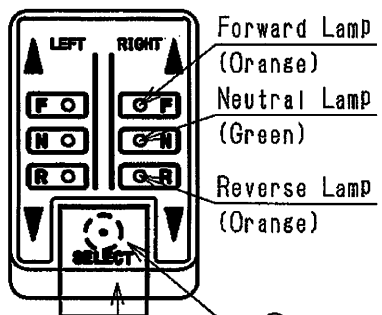

- *Indicates the shift position with a lamp.
- *The neutral lamp flashes during neutral throttle operation.
- *All lamps flash when the alarm is given.

To the buzzer

To the buzzer

To the starboard Control Unit via Harness Remote Control

To the port Control Unit Via Harness Remote Control

HOW TO OPERATE

Initial operation after power "ON"

1. With power "ON", and the hand lever in the "Neutral" position, the system will be in the neutral idle condition.
2. (1) Set the handle lever to the "Neutral" position.
(2) The green neutral lamp(s) lights indicating the control is operational.

NOTE

IF the hand lever(s) are moved to a forward or reverse gear position while power is not applied to the control system, and then power is applied, control system will not become operational unit until the hand lever(s) are moved into the neutral position. The green neutral lamp(s) then lights indicating the control is operational.

3. When other control stations are required for operation that are connected to R/C-2, R/C-3, R/C-4 and R/C-5 perform the following actions.
 - (1) Set the hand lever to the "Neutral" position.
 - (2) Open the switch cover and press the select switch.
 - (3) The green neutral lamp(s) then lights indicating the control is operational.

Shift & Throttle operation

WARNING

DO NOT ATTEMPT sudden forward to reverse the hand lever(s) operation. Sudden acceleration/ deceleration may cause damage to the boat or cause operator or passengers to be ejected from the boat.

- (1) Moving the hand lever from the neutral position to the forward or reverse detent causes the gear to shift to forward or reverse. The orange forward or reverse lamp(s) light to indicate forward or reverse gear position obtained.
- (2) Moving the hand lever past the Forward or reverse detent causes the engine into throttle operation and the boat will accelerate.

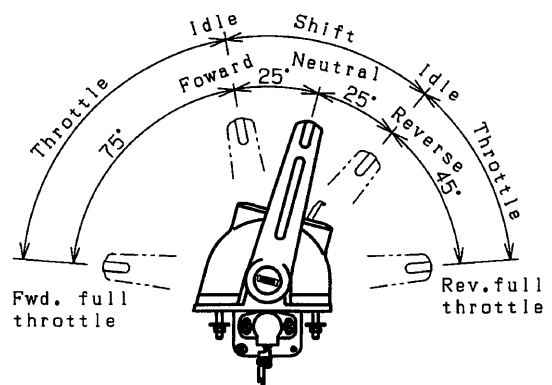

Lever stroke and output (See p. 18 "Adjusting the control unit")

Lever stroke	Shift output		Throttle output	
	Forward switch	Reverse switch	Output	Idle validation switch
Forward throttle range	Closed	Open	Forward Throttle Output	Open
Forward idle	Closed	Open	Idle Throttle Output	Closed
Neutral	Open	Open		
Reverse idle	Open	Closed	Reverse Throttle Output	Open
Reverse throttle range	Open	Closed		

Neutral throttle operation

1. Set the hand lever to the "NEUTRAL" position.
2. Open the switch cover located on the top of the control head and move the hand lever to the forward gear position while pressing the station select switch.
3. The green neutral lamp flashes and the neutral throttle operation is activated.
Neutral throttle operation will remain active until properly deactivated.

To Cancel Neutral Throttle Operation

1. Set the hand lever to the "NEUTRAL" position.
2. Open the switch cover and press and release the select switch.
After the release of the select switch green neutral lamp will stop flashing indicating deactivation of the neutral throttle operation.

Station transfer for 2, 3, 4 and 5 station operation from a neutral position

1. Set the hand lever(s) of the selected control to the neutral position, open the switch cover, press and release the select switch. A continues green neutral lamp(s) indicates the control station is active.

Station transfer for 2, 3, 4 and 5 station operation from a forward throttle position

1. Set the hand lever(s) of the selected control to the neutral position, open the switch cover, press and release the select switch. A continues green neutral lamp(s) indicates the control station is active.
2. The operator has 4 seconds to move hand levers and match the throttle position of the last active control station. Continues orange forward lamp(s) indicates control station is active.

NOTE

Keeping the hand lever of the last active control station in the neutral position, will result in control system automatically returning the control system to a neutral idle condition.

Continues green neutral lamp(s) indicates the control station active and system is a neutral idle condition.

INSTALLING THE CONTROL HEAD

⚠ CAUTION

Install the control head in a place from where the engine can be stopped anytime.

Select a flat place convenient for operation and installation.

- (1) Drill the mount holes by using an attached template.
- (2) Install with auxiliary washer and unit.

Tightening Torque: 2.9~4.4N·m {30~45kgf·cm}

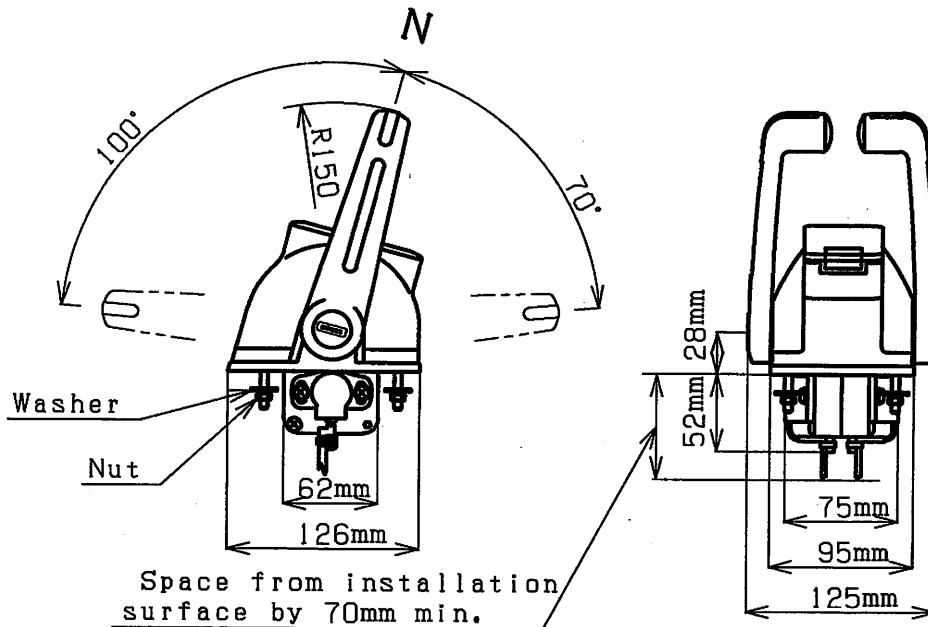

⚠ CAUTION

Mount the control head within 60 degrees from horizontal.

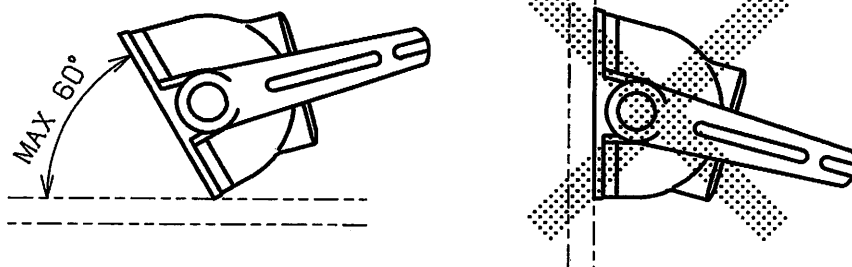

INSTALLING THE CONTROL UNIT

⚠ CAUTION

Ingress of water into the unit may cause failure

(1) Install so that the harness comes from the bottom side.

(2) Install in a place free from effect of the sea breeze and seawater.

Avoid a place where the ambient temperature rises above 75°C.

Note: Install the control unit so that the Cover comes in front.

- (1) Drill the mount holes by using an attached template.
- (2) Install with auxiliary pan head machine screw or tapping screw.

Installation with pan head machine screw

Installation plate thickness : 3 ~ 20 mm

Mount hole dia : ϕ 7 mm

Tightening torque : 4.9 ~ 7.8 N · m { 50 ~ 80 kgf · cm }

Installation with tapping screw

Installation plate thickness : 1.5 mm Min.

Pilot hole dia : ϕ 3 mm

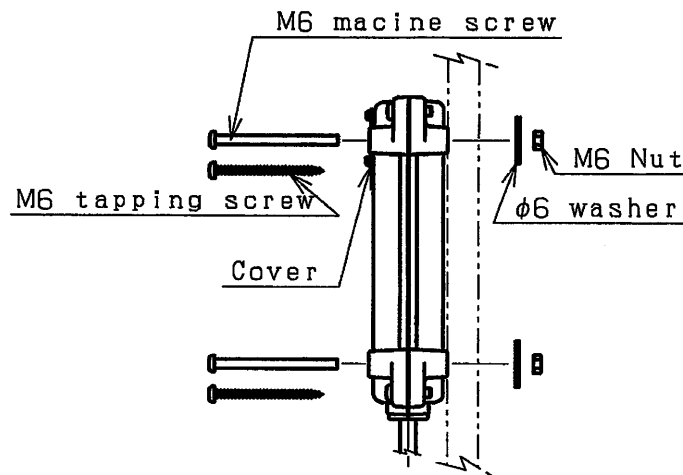

CONNECTING THE CONTROL HEAD AND CONTROL UNIT

⚠ CAUTION

Connect the coupler firmly.
These units may fail to operate when the coupler is not connected firmly.

- (1) Connection of the first control head
*Connect the harness remote control to the red-taped harness of the control head and connect it to the R/C-1 of the port control unit.
*Connect the harness remote control to the green-taped harness of the control head and connect it to the R/C-1 of the starboard control unit.
Note: Be sure to connect the control head to the R/C-1 of the each control unit.
- (2) Connection of the second control head if applicable
*Carry out connection to the R/C-2 the each control as described in (1).
- (3) Connection of the third control head if applicable
*Carry out connection to the R/C-3 the each control as described in (1).
- (4) Connection of the fourth control head if applicable
*Carry out connection to the R/C-4 the each control as described in (1).
- (5) Connection of the fifth control head if applicable
*Carry out connection to the R/C-5 the each control as described in (1).

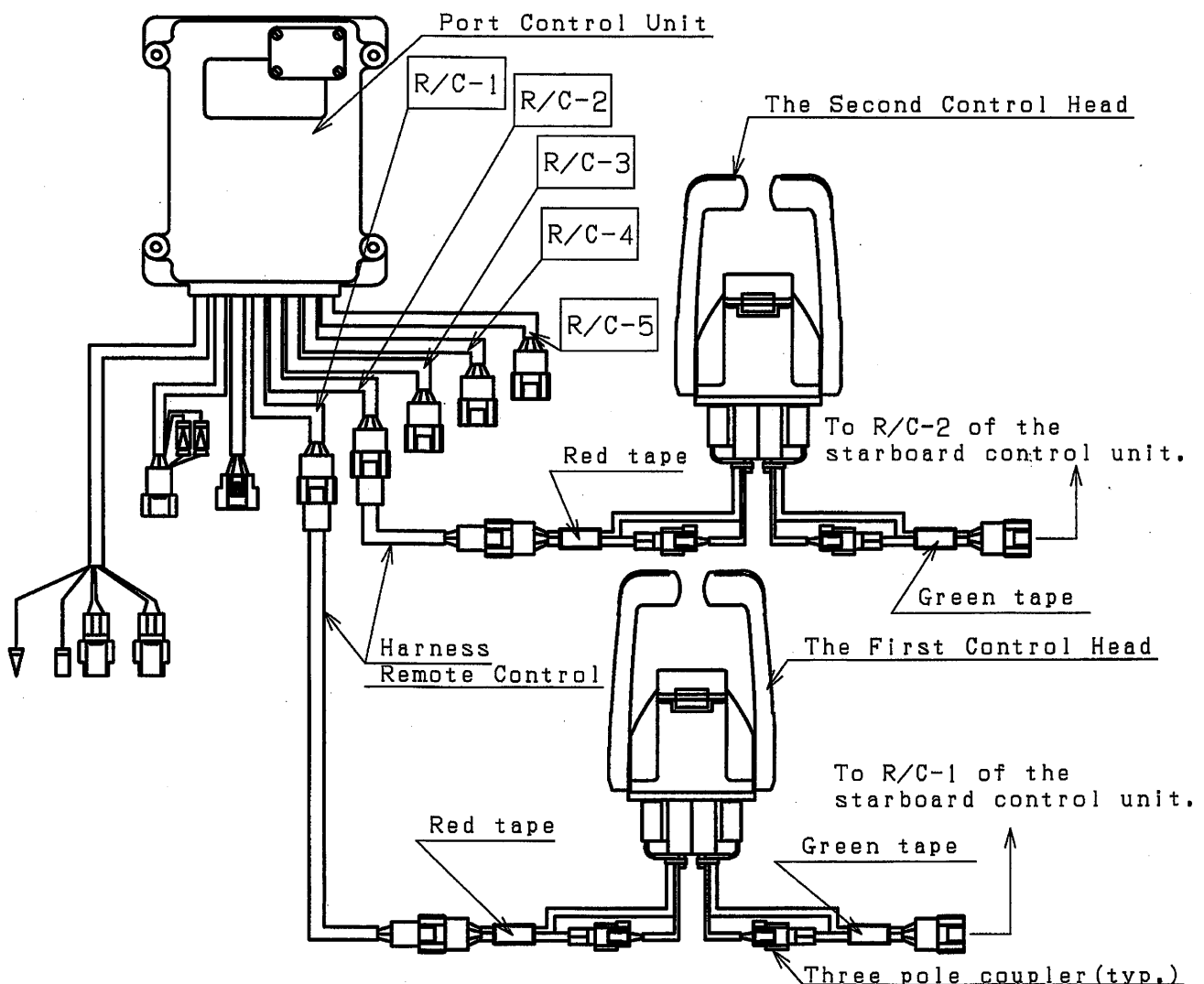

CONNECTING THE ENGINE AND CONTROL UNIT

⚠ CAUTION

Use the correct Harness Shift/Throttle, Type1, Type2 or Type3, for your engine. Failure to use the correct Harness Shift/Throttle may cause un-expected engine and/or gear movements when you operate the control system.

- (1) Connect the Harness Shift/Throttle to the SFT/THR Harness of the control unit.
- (2) Connect the other end of the Harness Shift/Throttle to the engine and gear referring to the engine and gear instruction.

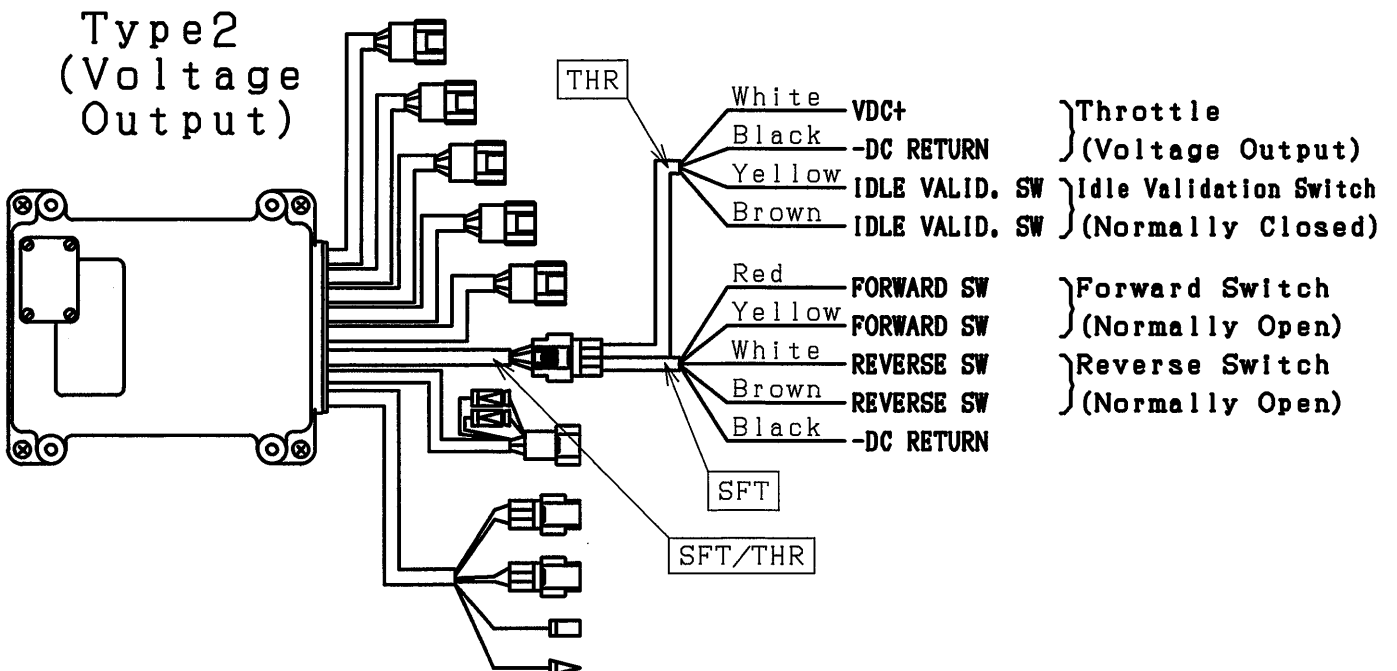
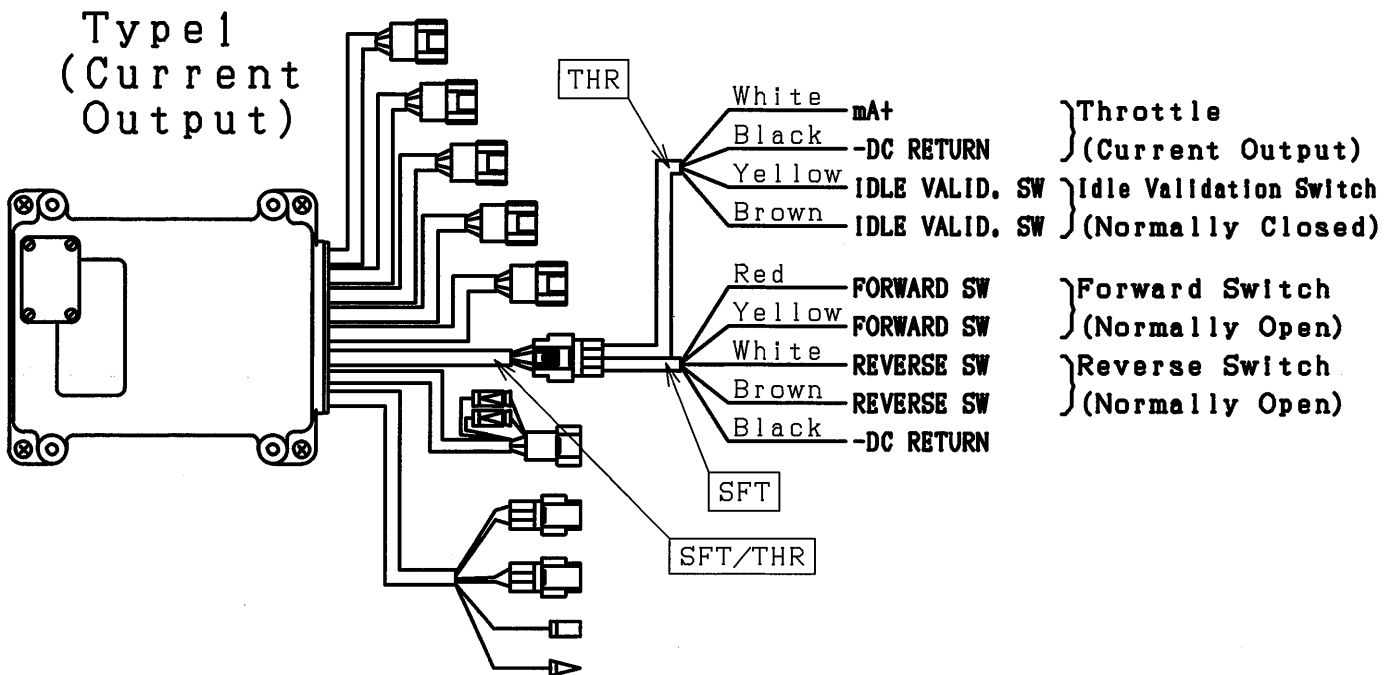

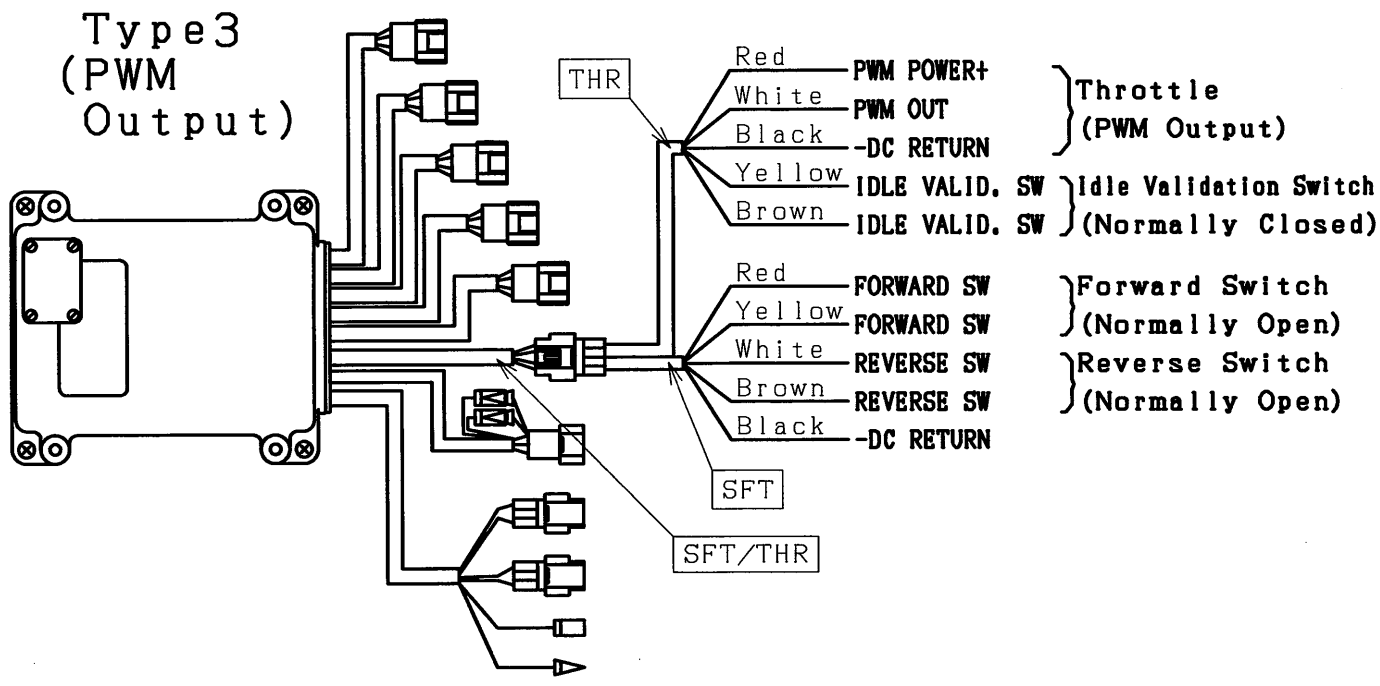

NOTE:
 It is not necessary to connect yellow, brown wires (for Idle Valid. SW) to engine unless it is required by engine specification.
 *Please refer to engine manual.

NOTE:
 It is not necessary to connect "SFT" black wire to gear unless it is required by gear specification.
 *Please refer to gear manual.

CONNECTING THE HARNESS POWER SUPPLY

⚠ CAUTION

To ensure the safety, the duplex power line system is provided. Be sure to connect both lines.

The display panel shows an alarm message when only one power line is connected.

Do not disconnect the power harness with the control unit after connecting the power harness with battery (power supply).

Use circuit breaker or battery switch to turn off the power.

- (1) Connect the Power Harness with the control unit before connecting each power harness with battery (power supply).
- (2) Connect each black wire of the power harness directly to (-) of battery (power supply).
- (3) Connect each white wire of the power harness via a 10 amp circuit breaker or fuse to (+) of battery (power supply).

Note: If two more battery is provided, connect each power switch.

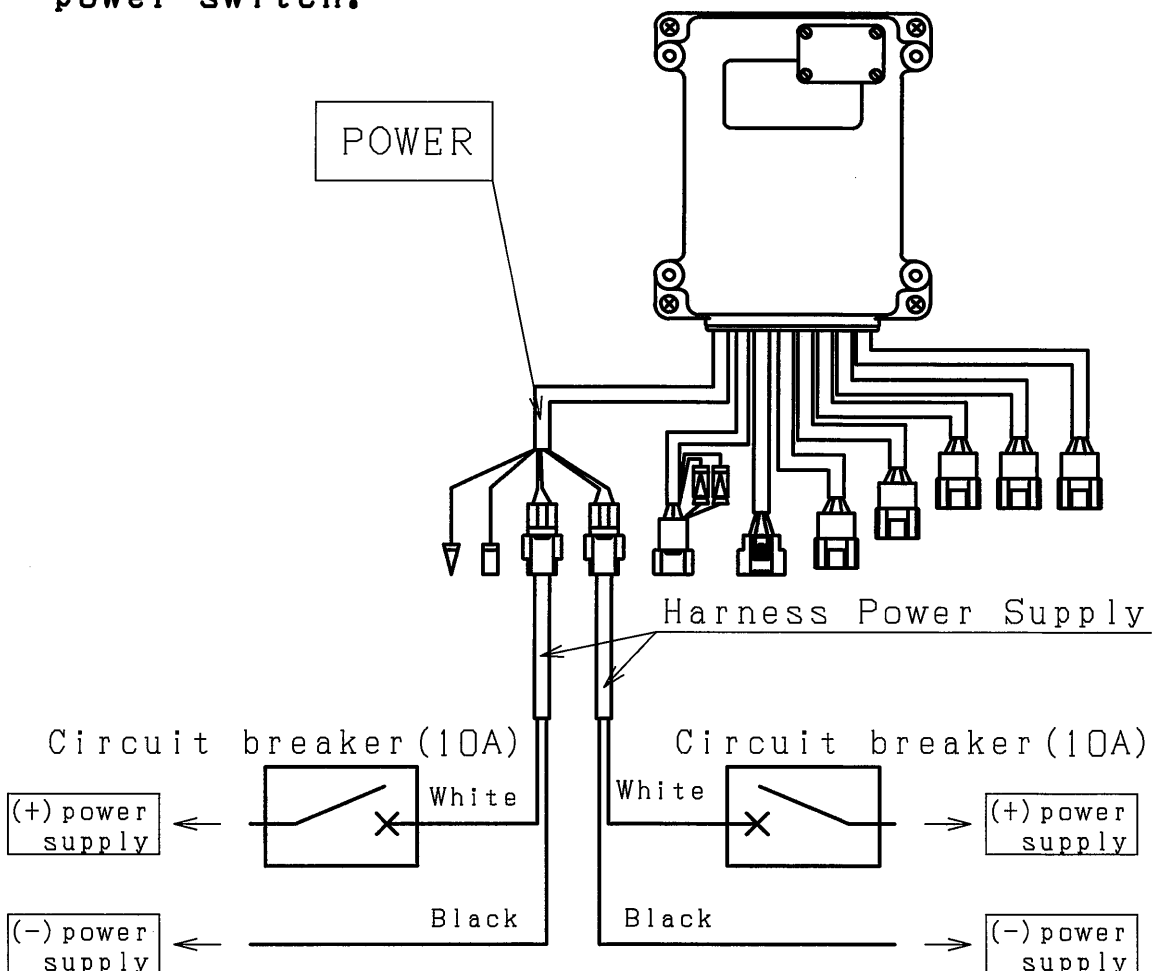

CONNECTING THE COMMUNICATION HARNESS

⚠ CAUTION

Turn off circuit breaker or battery switch before connect or disconnect the communication harness with the control unit.

Connect the two control units by the communication harness, which has 10-pole couplers at the both end, in dual engine system.

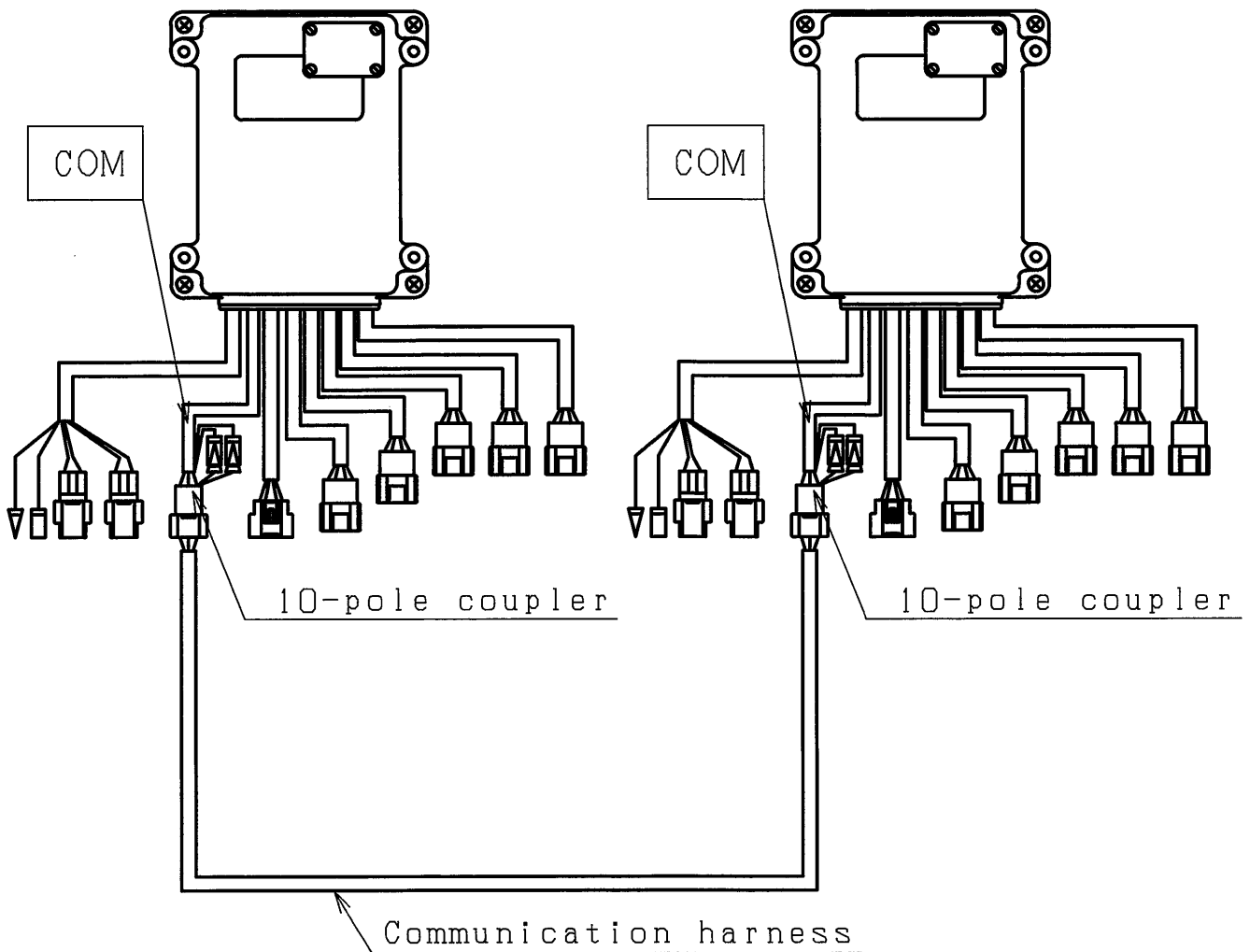

CONNECTING THE DIM HARNESS

- (1) Connect the Dim Harness brown line to the (+) wire of navigation light.
- (2) Connect the Dim Harness yellow line to the (-) wire of navigation light.

Note:The Dim Harness connection is not mandatory.

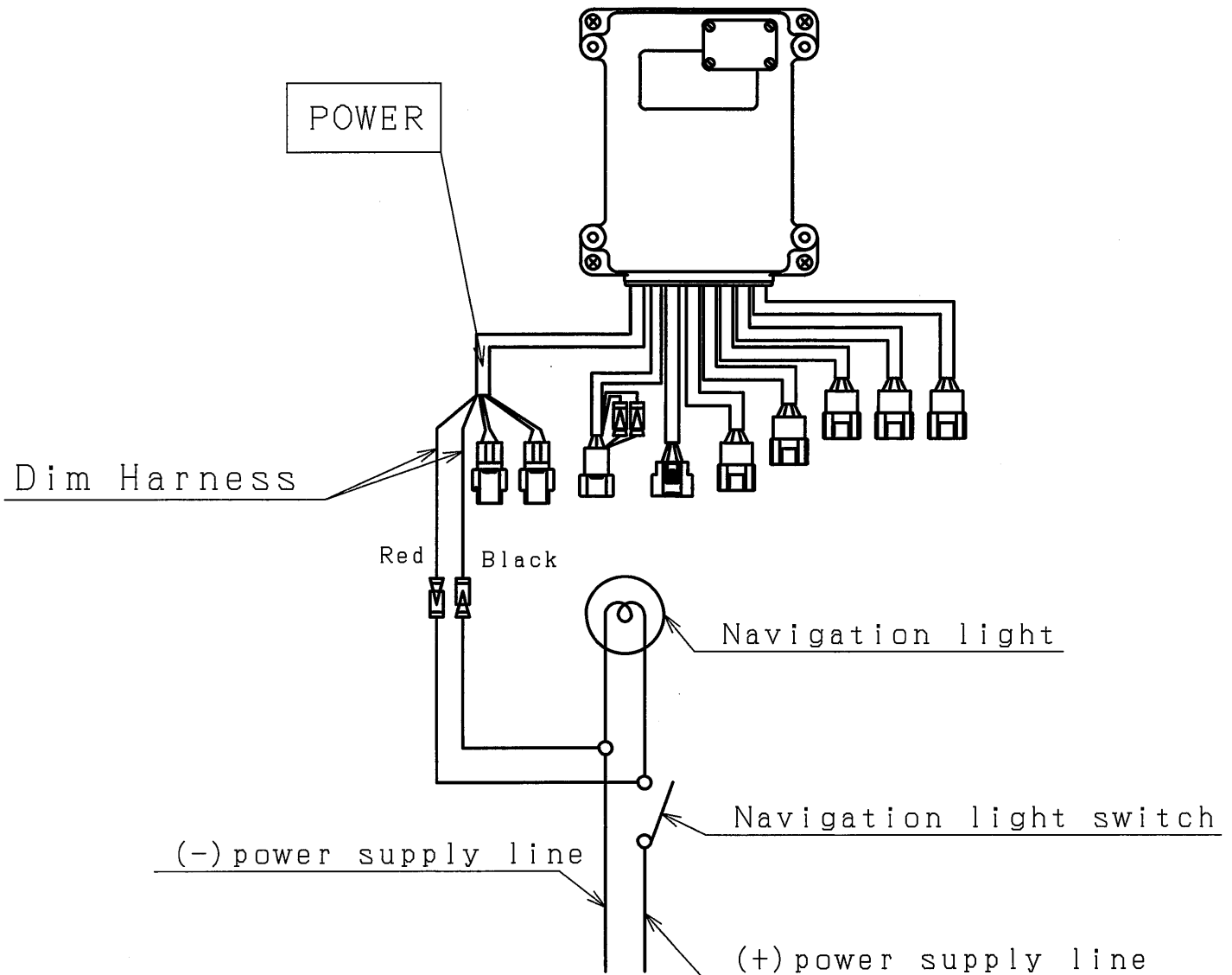

OVERALL WIRING DIAGRAM

The diagram below shows a case with two engines operated from two control heads.

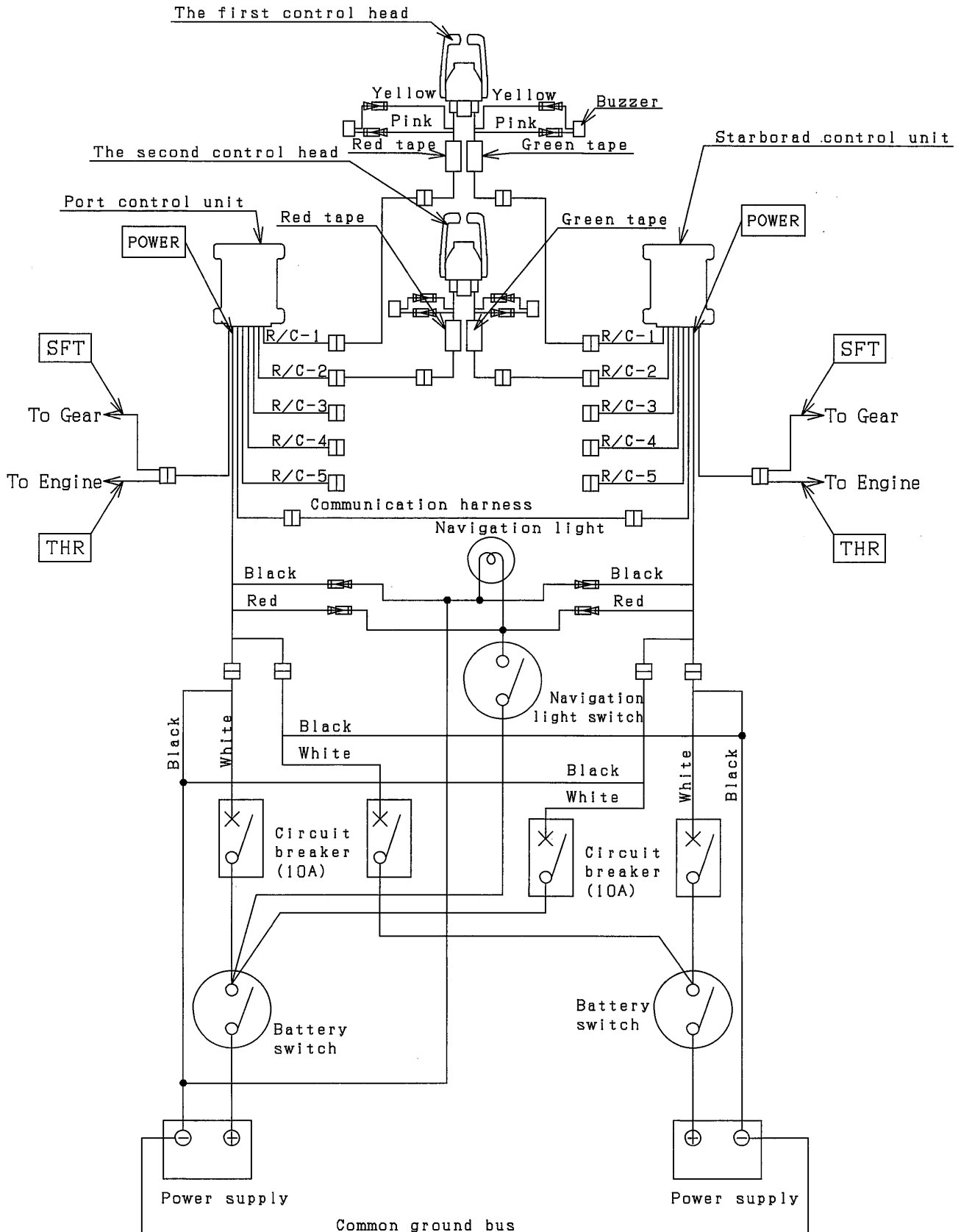

ADJUSTING THE CONTROL UNIT

⚠ CAUTION

Changes will be effective after cycling power.

When the control output is not match with the engine and gear, adjust by the switch in the control unit as follows.

- (1) Turn off the power.
- (2) Remove the cover, and adjust the switch as required.
- (3) Install the cover with tightening torque of 1.0~1.7N·m.

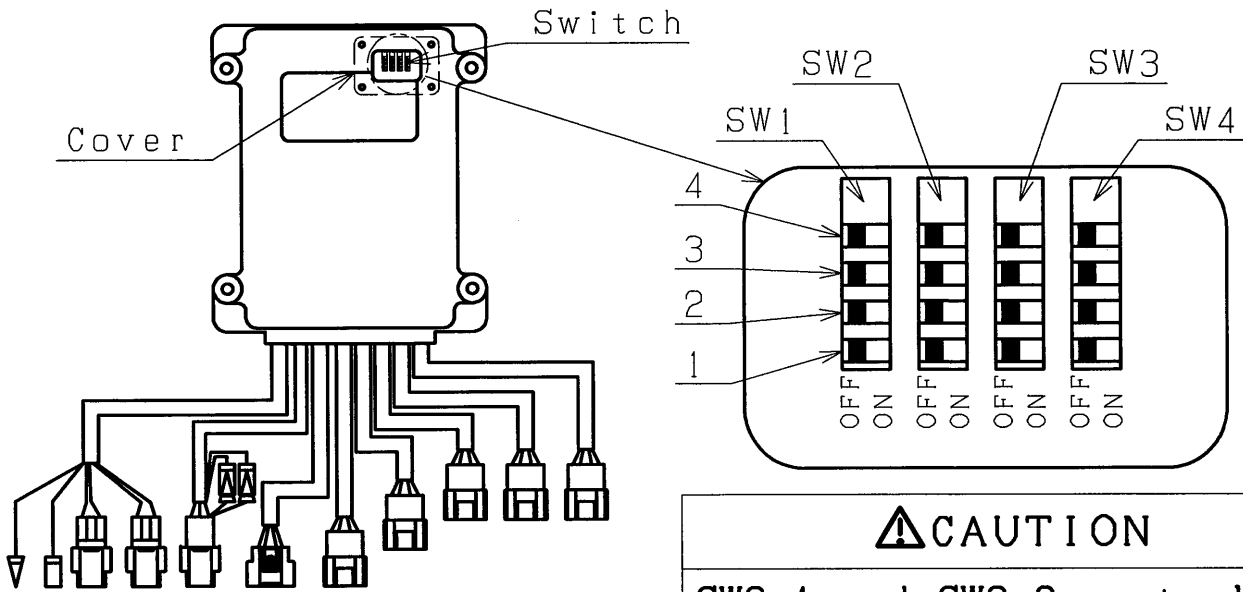

List of switch functions

⚠ CAUTION

SW3-1 and SW3-3 must always be set in the "OFF" position.

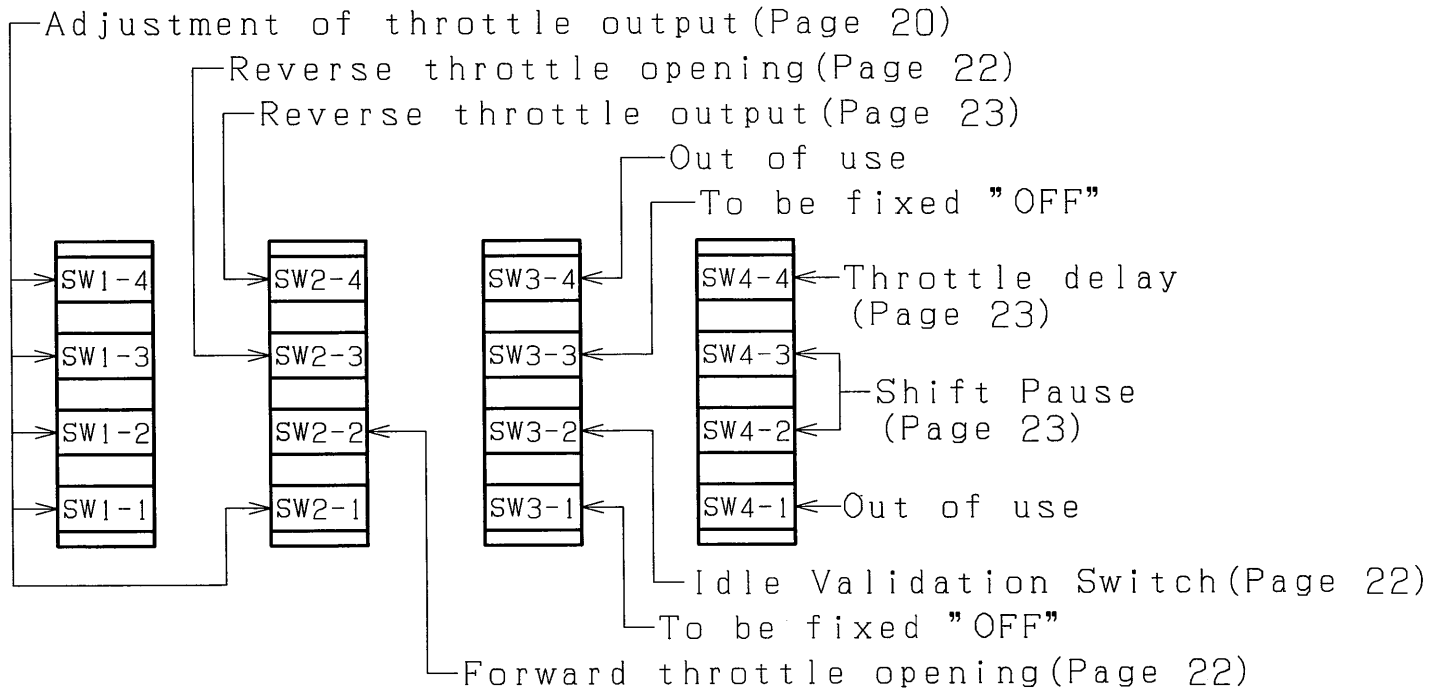

1. Setting the throttle output

The throttle output can be selected with SW1-1, 2, 3, 4 and SW2-1.

Select "Output type" refer to page 2.

Before setting dip switches, make sure all switches are set to OFF.

Type 1 (Current Output)

Refer to the table 1.

- (1) The relation of an engine, switches and the output is shown in heavy-line frame in table 1.
- (2) Before shipping, output is set to the rated value of MTU.
- (3) For more options, there are some additional adjustments.

Table 1

Engine	SW1-1	SW1-2	SW1-3	SW1-4	SW2-1	Idle Output	Forward Full Throttle Output
MTU (except 183, 396)	OFF	OFF	OFF	OFF	OFF	4.0mA	20.0mA
Additional Adjustments	ON	OFF	OFF	OFF	OFF	4.0mA	20.5mA
	OFF	ON	OFF	OFF	OFF	4.0mA	21.0mA
	ON	ON	OFF	OFF	OFF	4.0mA	19.5mA
	OFF	OFF	ON	OFF	OFF	4.0mA	19.0mA
	ON	OFF	ON	OFF	OFF	4.5mA	20.0mA
	OFF	ON	ON	OFF	OFF	4.5mA	20.5mA
	OFF	OFF	OFF	ON	OFF	4.5mA	21.0mA
	ON	OFF	OFF	ON	OFF	4.5mA	19.5mA
	OFF	ON	OFF	ON	OFF	4.5mA	19.0mA
	ON	ON	OFF	ON	OFF	5.0mA	20.0mA
	OFF	OFF	ON	ON	OFF	5.0mA	20.5mA
	ON	OFF	ON	ON	OFF	5.0mA	21.0mA
	OFF	ON	ON	ON	OFF	5.0mA	19.5mA
	OFF	OFF	OFF	OFF	ON	5.0mA	19.0mA
	ON	OFF	OFF	OFF	ON	3.5mA	20.0mA
	OFF	ON	OFF	OFF	ON	3.5mA	20.5mA
	ON	ON	OFF	OFF	ON	3.5mA	21.0mA
	OFF	OFF	ON	OFF	ON	3.5mA	19.5mA
	ON	OFF	ON	OFF	ON	3.5mA	19.0mA
	OFF	ON	ON	OFF	ON	3.0mA	20.0mA
	OFF	OFF	OFF	ON	ON	3.0mA	20.5mA
	ON	OFF	OFF	ON	ON	3.0mA	21.0mA
	OFF	ON	OFF	ON	ON	3.0mA	19.5mA
	ON	ON	OFF	ON	ON	3.0mA	19.0mA
OFF	OFF	ON	ON	ON	4.0mA	20.0mA	
ON	OFF	ON	ON	ON	4.0mA	20.0mA	
OFF	ON	ON	ON	ON	4.0mA	20.0mA	
Reserved for Type3	ON	ON	ON	*	*	-	-

※Before shipment, the switches are set to OFF (4.0mA to 20.0mA output).

Type 2 (Voltage Output)

Refer to the table 2.

- (1) The relation of an engine, switches and the output is shown in heavy-line frame in table 2.
- (2) Set the output by using SW1-1, 2, 3, 4 and SW2-1 to meet the rated output value of desired engine.
- (3) For more options, there are some additional adjustments.

Table 2

Engine	SW1-1	SW1-2	SW1-3	SW1-4	SW2-1	Idle Output	Forward Full Throttle Output
Detroit Diesel John Deere	OFF	OFF	OFF	OFF	OFF	0.50V	4.50V
Cummins Quantum (without IVS)	OFF	OFF	OFF	ON	ON	0.65V	4.35V
Volks Wagen	OFF	ON	OFF	OFF	OFF	0.20V	4.53V
Additional Adjustments	OFF	OFF	OFF	OFF	ON	0.50V	4.35V
				ON	OFF	0.65V	4.50V
	ON	OFF	OFF	OFF	OFF	0.90V	4.50V
				OFF	ON	0.90V	4.35V
				ON	OFF	1.05V	4.50V
				ON	ON	1.05V	4.35V
	OFF	ON	OFF	OFF	ON	0.20V	4.35V
				ON	OFF	0.40V	4.53V
				ON	ON	0.40V	4.35V
	ON	ON	OFF	OFF	OFF	0.40V	3.00V
				OFF	ON	0.40V	2.90V
				ON	OFF	0.50V	3.00V
				ON	ON	0.50V	2.90V
	OFF	OFF	ON	OFF	OFF	0.90V to 1.20V	4.00V
				OFF	ON	0.90V to 1.20V	3.88V
				ON	OFF	1.02V to 1.32V	4.00V
				ON	ON	1.02V to 1.32V	3.88V
	ON	OFF	ON	OFF	OFF	0.30V	4.50V
				OFF	ON	0.30V	3.90V
				ON	OFF	0.75V	4.50V
				ON	ON	0.75V	3.90V
	OFF	ON	ON	OFF	OFF	0.60V	2.70V
				OFF	ON	0.60V	2.88V
				ON	OFF	0.80V	2.76V
ON				ON	0.80V	2.88V	
Reserved for Type3	ON	ON	ON	*	*	-	-

※Before shipment, the switches are set to OFF (Engine Type: Detroit Diesel).

Type 3 (PWM Output)

Refer to the table 3.

- (1) The relation of an engine, switches and the output is shown in heavy-line frame in table 3.
- (2) Set the output by using SW1-1, 2, 3, 4 and SW2-1 to meet the rated output value of desired engine.
- (3) For more options, there are some additional adjustments.

Table 3

Engine	SW1-1	SW1-2	SW1-3	SW1-4	SW2-1	Idle Output (duty cycle)	Forward Full Throttle Output (duty cycle)
Caterpillar	ON	ON	ON	OFF	OFF	8%	92%
Additional Adjustments	ON	ON	ON	OFF	ON	8%	94%
				ON	OFF	6%	92%
				ON	ON	6%	94%

2. Setting the idle validation switch

The idle switch can be utilized.

See "Shift & Throttle operation" on page 8.

Set with SW3-2.

SW3-2	FUNCTION
OFF	Effective
ON	Ineffective

※Before shipment, the switch is set to OFF (Effective).

3. Setting the throttle opening

This function facilitate fine throttle adjustment over range from idle to low RPM range. This setting also allows decrease in the shock after shift in when the hand lever is operated suddenly.

(1) Setting the forward throttle opening

Set with SW2-2.

SW2-2	FUNCTION
OFF	Forward throttle opening 1
ON	Forward throttle opening 2

※Before shipment, the switch is set to OFF (Opening 1).

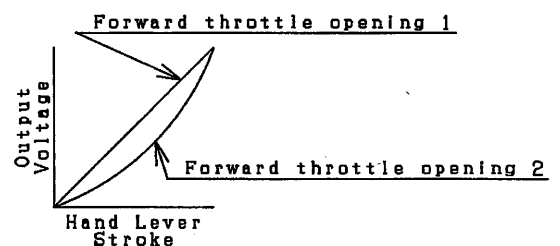

(2) Setting the reverse throttle opening

Set with SW2-3.

SW2-3	FUNCTION
OFF	Reverse throttle opening 1
ON	Reverse throttle opening 2

※Before shipment, the switch is set to OFF (Opening 1).

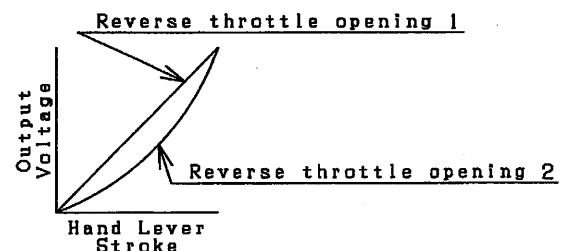

4. Setting the reverse throttle output

This is to set the throttle output for the full reverse throttle stroke.

Set with SW2-4.

SW2-4	FUNCTION
OFF	100% of the forward full open
ON	60% of the forward full open

※Before shipment, the switch is set to OFF (100% of the full forward throttle stroke).

5. Setting the throttle delay

This is to delay the start of the throttle operation when the hand lever is shifted suddenly from neutral to throttle operation range.

Delay time: 1 s e c

Set with SW4-4.

SW4-4	FUNCTION
OFF	No throttle delay
ON	Throttle delay

※Before shipment, the switch is set to OFF (no throttle delay).

6. Setting the shift pause

This is to set the time from the end of throttle operation to start of the shift operation when the hand lever is suddenly shifted from the throttle operation range to neutral.

The set time can be varied with the hand lever position.

Shift pauses of 0, 2, 4 and 6 seconds for rapid hand lever operation from forward full throttle can be selected.

Set with SW4-2 and 3.

SW4-2	SW4-3	FUNCTION
OFF	OFF	No shift pause
ON	OFF	2 seconds
OFF	ON	4 seconds
ON	ON	6 seconds

※Before shipment, both the switches are set to OFF (no shift pause).

OPERATION CHECK

Carry out operation check as follows when the installation work is over.

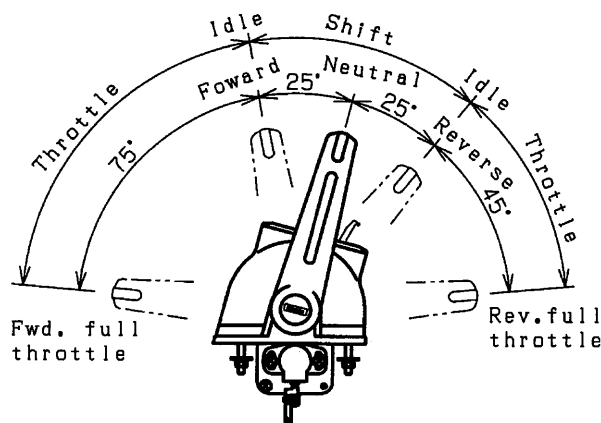

1. Shift and throttle operation check

Step	Hand lever operation	Description (engine side)
1	Neutral → Forward	Gear shifted from neutral to forward
2	Forward → Forward full open	Throttle shifted from fully closed to full open
3	Forward full open → Neutral	Throttle shifted from full open to fully closed Gear shifted from forward to neutral
4	Neutral → Reverse	Gear shifted from neutral to reverse
5	Reverse → Reverse full open	Throttle shifted from fully closed to full open
6	Reverse full open → Neutral	Throttle shifted from full open to fully closed Gear shifted from reverse to neutral

When the correct operation can not be made, change the operation mode. (See “Adjusting the control unit” on page 19)

When the forward/neutral/reverse lamp flashes, refer to “Alarm indication” on page 25.

ALARM INDICATION

In the case of system fault, the failed point is indicated with forward/neutral/reverse lamp flashing frequency and optional buzzer. All of forward, neutral, and reverse lamps flash simultaneously.

Flashing frequency	Cause	Countermeasure	Reference
Twice	(1) Control head is not connected to R/C-1 of control unit. (2) Control head and control unit are not connected correctly. (3) Three-pole coupler of control head is disconnected. (4) Control head harness with wire breakage or shorting (5) Harness remote control with wire breakage or shorting (6) R/C-1, 2, 3, 4 and 5 harnesses of control unit with wire breakage or shorting	(1) Connect the control head to R/C-1. (2) Reconnect the control head and control unit. (3) Connect the three-pole coupler. (4) Consult your dealer. (5) Replace the harness remote control. (6) Consult your dealer.	page 12 page 12 page 12 page 12
Threetimes	(1) One of duplex power lines is disconnected. (2) Either circuit breaker is OFF. (3) Harness power supply coupler is not connected correctly. (4) Battery voltage is beyond the operating voltage range. (5) Harness power supply with wire breakage (6) POWER harness of the control unit is broken	(1) Connect both lines. (2) Turn ON both circuit breakers. (3) Reconnect the coupler of harness power supply. (4) Use the battery within the operating voltage range. (5) Replace the harness power supply. (6) Consult your dealer.	page 15 page 15 page 15 page 2 page 15
Fourtimes	(1) Select switch is kept pressed. (2) Control head harness is shorted. (3) Harness remote control is shorted. (4) R/C-1, 2, 3, 4 and 5 harnesses of control unit with short	(1) Reset the select switch in a free state. (2) Consult your dealer. (3) Replace the harness remote control. (4) Consult your dealer.	page 7 page 4, 12
Sixtimes	(1) Communication harness with wire breakage or shorting (2) One of the control units has no power.	(1) Replace the communication harness. (2) Turn ON circuit breaker.	page 16

CHECK POINTS IN CASE OF TROUBLE

Always consult this table first when any probable trouble phenomenon is observed during operation.

Symptom	Cause	Countermeasure
Not operating even when power supply is ON.	(1) Harness power is not connected correctly. (2) Circuit breaker OFF	(1) Connect the harness power correctly. (See page 15) (2) Turn ON circuit breaker.
Forward/neutral/reverse lamps flashing simultaneously.	(1) Abnormality in the system	(1) Refer to "Alarm indication" on page 25.
No forward/neutral/reverse lamp ON.	(1) Hand lever is not in neutral during initial operation. (2) R/C-1 of the control unit is not connected with the control head.	(1) Set the hand lever to NEUTRAL with power ON. (See Page 8) (2) Connect the control head to R/C-1. (See page 12)
Any one of forward/neutral/reverse lamps not ON.	(1) Wire breakage in control head harness (2) Wire breakage in harness remote control (3) Failure in lamp	(1) Consult your dealer. (2) Replace the harness remote control. (See page 12) (3) Consult your dealer.
Forward/neutral/reverse lamps are ON correctly, but the clutch can not be engaged.	(1) Harness shift/throttle is not connected to the clutch correctly. (2) Wire breakage in harness shift/throttle	(1) Connect the harness shift/throttle correctly. (See page 13 and 14) (2) Consult your dealer.
Forward/neutral/reverse lamps are ON correctly, but the engine speed does not rise.	(1) Harness shift/throttle is not connected to the engine correctly. (2) Wire breakage in harness shift/throttle	(1) Connect the harness shift/throttle correctly. (See page 13 and 14) (2) Consult your dealer.
Engine does not start.	(1) Low battery voltage	(1) Charge the battery.
Neutral throttle operation cannot be made.	(1) Neutral throttle operation is not set correctly. (2) Failure in select switch	(1) Carry out setting correctly. (See page 7) (2) Consult your dealer.
Operation position can not be selected.	(1) Hand lever not in the neutral position (2) Failure in select switch	(1) Set the hand lever to NEUTRAL. (2) Consult your dealer.

MAINTENANCE AND SERVICE

Repair or replace any damaged part.

Control head

- (1) After use, wash with city water to prevent corrosion.
- (2) Never use grease because this contains electronic components.

Control unit

- (1) After use, wash with city water to prevent corrosion.
- (2) Never use grease because this contains electronic components.

Harness

- (1) Check for wire breakage and damage periodically.
- (2) Check the coupler, etc. for disconnection periodically.

CONTROL HEAD TEMPLATE

Tear on the perforated line

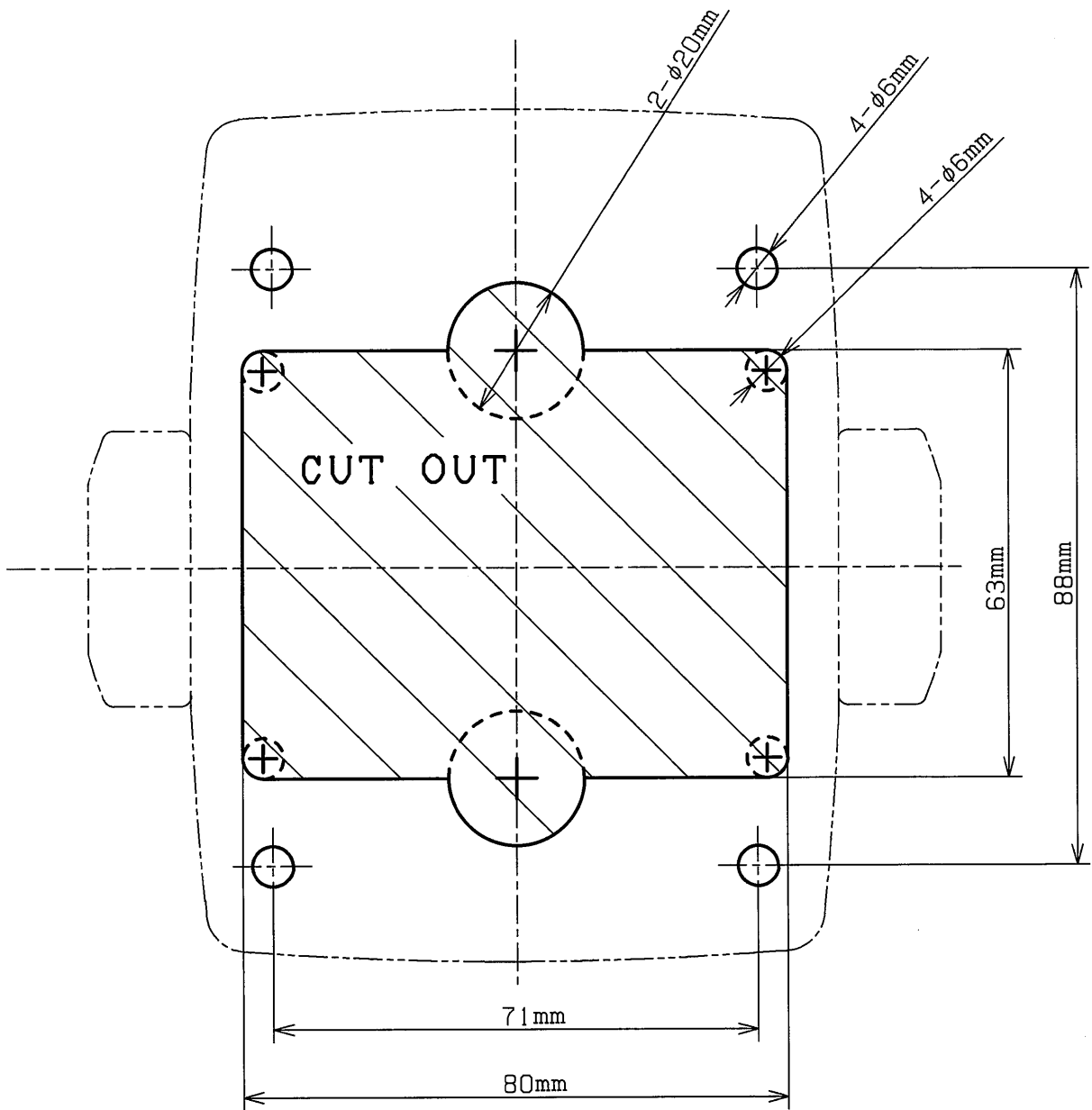

CONTROL UNIT TEMPALTE

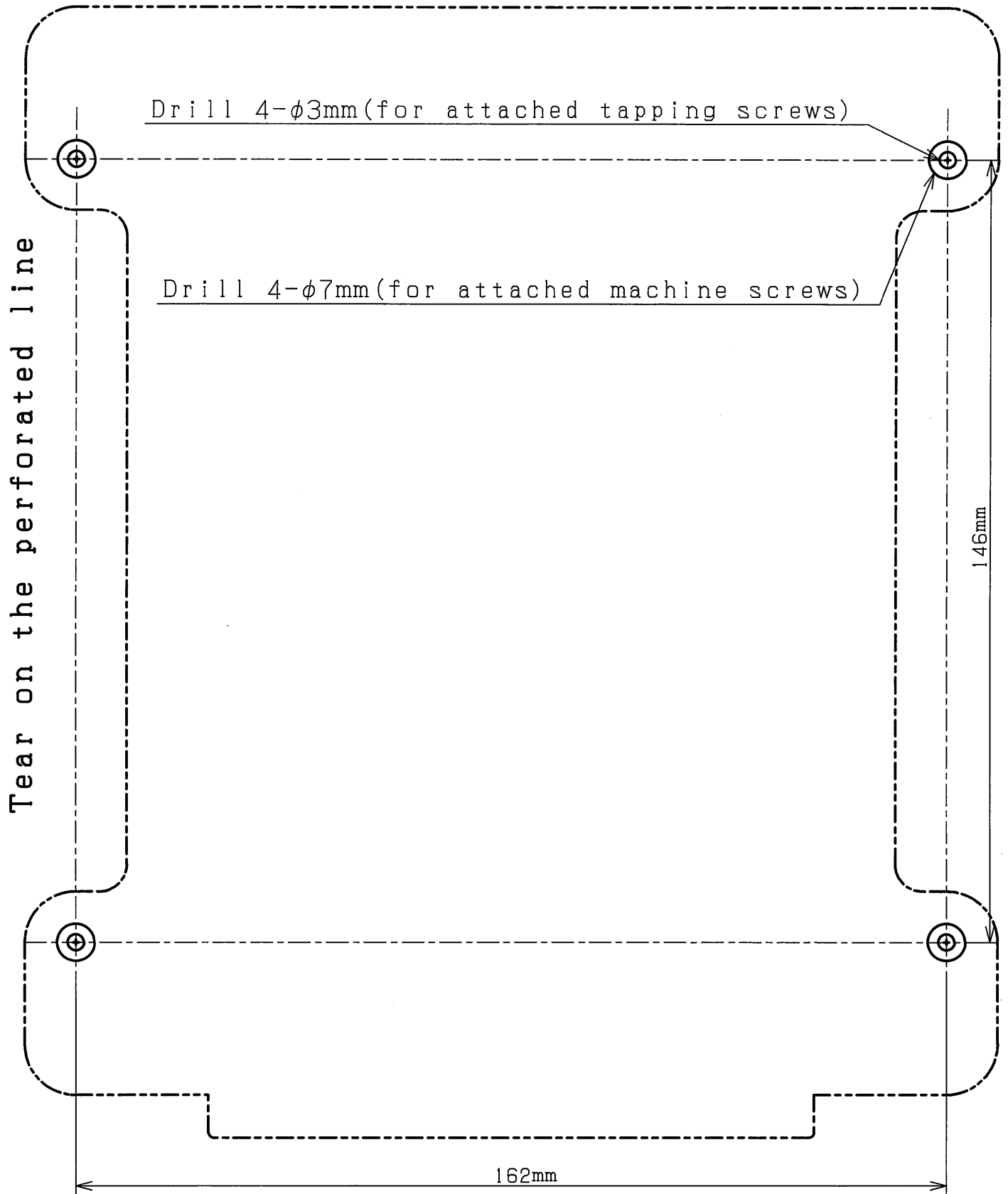

NHK TELEFLEX MORSE CO., LTD.

**3-21-10, SHIN-YOKOHAMA, KOHOKU-KU, YOKOHAMA,
222-0033, JAPAN**

PHONE:(045)475-8905 FAX:(045)475-8908