

**NHK MEC**

***KE-4<sup>+</sup>***

***ELECTRONIC CONTROL SYSTEM***

***INSTRUCTION MANUAL***

# TABLE OF CONTENTS

INTRODUCTION .....	1
SAFETY PRECAUTIONS .....	1
INSTALLATION / REPAIR .....	1
PRODUCT COMPLIANCE .....	2
PRODUCT SPECIFICATIONS .....	2
PRODUCT FUNCTIONS .....	3
SINGLE ENGINE CONFIGURATION .....	4
→COMPONENTS LIST .....	5
DUAL ENGINE CONFIGURATION .....	6
→COMPONENTS LIST .....	7
TRIPLE ENGINE CONFIGURATION .....	8
→COMPONENTS LIST .....	9
QUAD ENGINE CONFIGURATION .....	10
→COMPONENTS LIST .....	11
CONTROL UNIT DETAILS .....	12
CONTROL HEAD DETAILS .....	13
ACTUATOR DETAILS .....	14
KE SYSTEM OPERATION .....	15
Initial Power ON & Control Head Lever Operation .....	15
Neutral Throttle Operation .....	16
Station Transfer .....	16
Synchronization Operation .....	16
DETERMINATION OF CABLE LENGTH .....	17
INSTALLING THE CONTROL HEAD .....	18
INSTALLING THE CONTROL UNIT .....	19
INSTALLING THE ACTUATOR .....	20
CONNECTING CONTROL HEAD AND CONTROL UNIT .....	21
CONNECTING ACTUATOR AND CONTROL UNIT .....	22
CONNECTING SIGP: START-IN-GEAR PROTECTION .....	23
CONNECTING POWER .....	24
CONNECTING THE SYNCHRONIZATION CIRCUIT .....	25
CONNECTING THE DIM HARNESS (OPTION) .....	26
CONNECTING BUZZER (OPTION) .....	27
CONNECTING TRIM CIRCUIT (OPTION) .....	28
CONNECTING IDLE SWITCH (OPTION) .....	29
CONNECTING TRIPLE SWITCH (OPTION) .....	30
CONNECTING QUAD SWITCH (OPTION) .....	31
PUSH-PULL CABLE INSTALLATION .....	32

## TABLE OF CONTENTS (continued)

ADJUSTING THE CONTROL UNIT .....	34
● shift mode .....	34
● shift stroke: forward .....	34
● shift stroke: reverse .....	35
● throttle mode .....	35
● forward throttle stroke .....	35
● reverse throttle stroke .....	36
● synchronization configuration .....	36
● forward throttle opening .....	36
● reverse throttle opening .....	36
● throttle delay .....	37
● shift pause .....	37
● triple & quad engine configuration (supplemental info) .....	37
● settings tool enable .....	37
OPERATION CHECK .....	38
● Shift and throttle operation check .....	38
● Confirmation of engine start .....	38
MANUAL OPERATION METHOD (OPTION) .....	39
ALARM CODES .....	40
TROUBLESHOOTING .....	42
MAINTENANCE AND SERVICE .....	43
CONTROL HEAD TEMPLATE .....	44
CONTROL UNIT TEMPLATE .....	45
IDLE / TRIPLE / QUAD SWITCH TEMPLATE .....	46

---

# INTRODUCTION

---

This manual has been prepared to ensure the correct operation of the standard configuration KE-4+ electronic remote control system. Be sure to read through this manual to understand the how system functions. Always keep the manual within your reach during operation. If your KE-4+ system also includes trolling control or handheld control options, please also refer to those additional manuals.

The KE-4+ system controls the shift (gear) and throttle (governor) of the vessel. It is recommended therefore to also read the instruction manuals of the vessel's engine and marine gear.

The specifications may be subject to change without notice (for upgrades), resulting in differences between the content of the manual and the product. In case of ambiguity or questions concerning the product or the manual, consult with your dealer.

---

## SAFETY PRECAUTIONS

---

This manual contains precautions under the following headers, which, if not observed, could result in personal injury or damage to property. Pay particular attention to these precautions.



Failure to comply with a Warning may result in an accident causing death or serious injury.



Failure to comply with a Caution may result in an accident causing light injury or damage to the product or properties.

---

## INSTALLATION / REPAIR

---

The installation of this product must be performed following all applicable installation and safety codes.

Only authorized personnel should perform disassembly and repair of this product; otherwise the warranty will be voided.

---

# PRODUCT COMPLIANCE

---

## 1. EUROPEAN UNION



RECREATIONAL CRAFT DIRECTIVE  
EMC DIRECTIVE

## 2. USCG

This control system provides start-in-gear protection meeting USCG requirements of 33 CFR Part 183, Subpart L.

## 3. ABYC, ISO

This control system meets applicable ABYC & ISO standards.

---

# PRODUCT SPECIFICATIONS

---

## 1. Electrical Performance

- Supply voltage: DC 9V to 30V (12V/24VDC common mode)
- Max. current of actuator: 16A or less (at 49N{5kgf} · 11lbf load)
- Current consumption (stand-by): 0.5A or less

## 2. Mechanical Performance (Actuator)

- Thrust
- Operating thrust : 147N {15kgf} · 33 lbf
- Constraint load : 343N {35kgf} · 77 lbf
- Stroke
- Shift: Forward or Reverse stroke (can be set separately) 26 / 30 / 34 / 40 mm
- Throttle: 80mm MAX.

## 3. Temperature Range

- Operating temperature: -20° C ~ +75° C
- Storage temperature : -40° C ~ +100° C

---

# PRODUCT FUNCTIONS

---

The KE-4+ electronic remote control system is capable of the following functions.

## 1. Main Functions

- Shift: Control head lever allows Forward/Neutral/Reverse operations of the vessel
- Throttle: Control head lever allows the acceleration & deceleration operations of the vessel
- Neutral throttle: Provides throttle only operation in order to warm up the engine
- Control Station Select: Allows transfer from one control station to another by pressing the SEL button on any control head; up to 4 control head stations are available
- Synch: Allows multi-engine speed synchronization by pressing the SYNC button on any control head; single lever synch and dual lever synch modes are available
- SIGP: Enables engine start up only when the vessel is in the neutral position; a safety feature
- Actuator settings: Allows various settings for actuator operation such as shift & throttle modes, push-pull cable stroke distances, etc. in order to match the KE-4+ system actuator outputs with a variety of engine and gearbox configurations. Settings are adjusted via the DIP switches accessible on the control unit.
- Alarm Codes: System errors are automatically detected and indicated via flashing LED-s on the control head; the last error code will also be displayed on the control unit alphanumeric display

The following options can also be added to the KE-4+ electronic remote control system.

## 2. Optional Functions

- Dim display: Decreases brightness of the LED on the control head during nighttime
- Buzzer: Combines an audio alarm to LED alarm codes
- Trim Circuit (for outboards): Master trim control switch available in the handle of the control head lever; in addition, circuit harness to connect to panel trim control switches for individual engine trim control in the case of multiple engines
- Idle control: Provides idle control of the engines via a 2-button switch / 1-LED display; incrementally increases throttle up to 20% of max. throttle
- Triple engine control: Provides options for control of center engine actuator from the port lever via a 1-button switch / 2-LED display
- Quadruple engine control: Provides options for control of inside engine actuators (center-port & center-starboard) and outside engines (port & starboard) via a 1-button switch / 2-LED display
- Mechanical backup: In case of electrical failure, enables manual operation of actuator lever via a mechanical control head
- Trolling control: Allows trolling speed control of the vessel via a 2-button switch / 1-LED display plus trolling unit & trolling actuators
- Handheld control: Provides a handheld / mobile version of the control head to be added to the system; attached to the main system via long harnesses.
- Settings Tool: Software version of the actuator settings; requires a laptop connection. Can be used as a substitute for the DIP switch procedure described in the main functions; particularly useful for multi-vessel settings management.

# SINGLE ENGINE CONFIGURATION

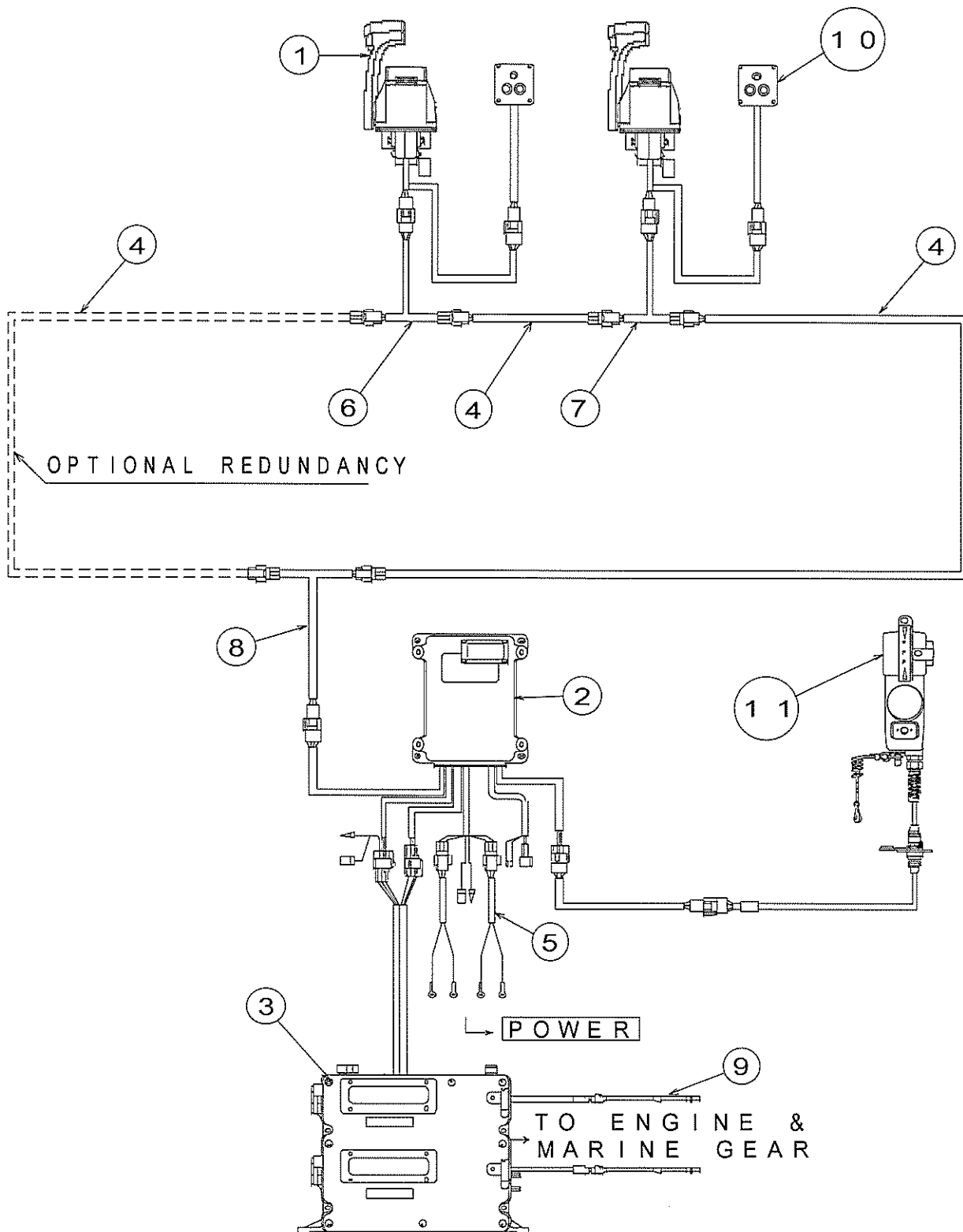

Note: The figure above is an example of a single engine / two control stations system with optional idle control switches and optional handheld control.

# COMPONENTS LIST

KE-4+ Component Parts List (Single)		Required Quantity			
		Single Engine			
		1	2	3	4
Description	Part number	1	2	3	4
① Control Head, Single w/o PTT	NM1002-00				
<i>PTT = power trim/tilt switch (o/b style) w/ PTT</i>	NM1001-00	1	2	3	4
<i>SST = stainless steel, (i/b style)</i> SST	NM1003-00				
② Control unit 12V/24V	NM1475-00				1
③ Actuator	NM0183-00				1
④ Bus Harness  2m 4m 6m 8m 10m 12m 14m 16m 18m 20m 24m 30m 40m 50m  1m = 39 inches   CAUTION Bus harness should not exceed 80m in total length; otherwise system performance could degrade.	NM0649-02				
	NM0649-04				
	NM0649-06				
	NM0649-08				
	NM0649-10				
	NM0649-12				
	NM0649-14	1	2	3	4
	NM0649-16				
	NM0649-18				
	NM0649-20				
	NM0649-24				
	NM0649-30				
	NM0649-40				
	NM0649-50				
⑤ Harness Power Supply	5m NM0414-28				2
	10m NM0414-33				
⑥ T-harness (R/C-1)	NM0647-09				1
⑦ T-harness (R/C)	NM0647-10	-	1	2	3
⑧ T-harness (SINGLE)	NM0647-11				1
⑨ Push - pull cable	TFXtreme, 33HPC				2
⑩ Idle Switch (optional)	NJ0765-00	1	2	3	4
⑪ Handheld control (optional)	Refer to handheld manual				
Circuit Breaker (optional)	20A NJ0514-00				2
Buzzer (optional)	12V NJ0596-00	1	2	3	4
	24V NJ0515-00				
SW extension harness (optional)	NM0647-08	1	2	3	4

Note: Refer to previous page for balloon references and system configuration.

# DUAL ENGINE CONFIGURATION

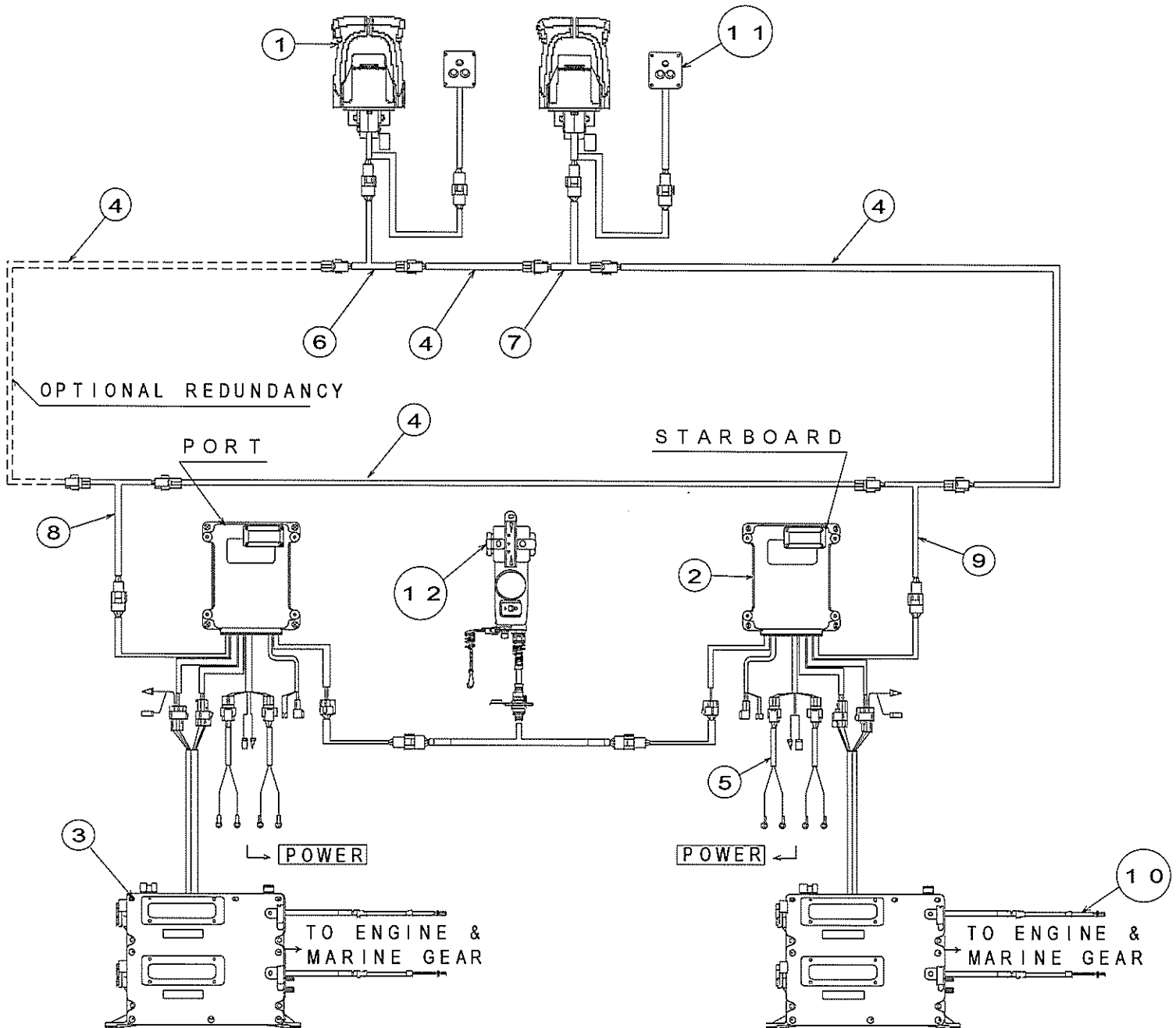

**Note:** The figure above is an example of a two engines / two control stations system with optional idle control switches and optional handheld control.

# COMPONENTS LIST

KE-4+ Component Parts List (Dual)		Required Quantity			
		Dual Engine			
		No. of stations			
Description	Part number	1	2	3	4
① Control Head, Twin w/ PTT	NM1051-00				
<i>PTT = power trim/tilt switch (o/b style)w/o PTT</i>	NM1052-00	1	2	3	4
<i>SST = stainless steel, (i/b style)</i> SST	NM1053-00				
② Control unit 12V/24V	NM1475-00	2			
③ Actuator	NM0183-00	2			
④ Bus Harness 2m 4m 6m 8m 10m 12m 14m 16m 18m 20m 24m 30m 40m 50m   <b>CAUTION</b> Bus harness should not exceed 80m in total length; otherwise system performance could degrade.	NM0649-02				
	NM0649-04				
	NM0649-06				
	NM0649-08				
	NM0649-10				
	NM0649-12				
	NM0649-14				
	NM0649-16	2	3	4	5
	NM0649-18				
	NM0649-20				
	NM0649-24				
	NM0649-30				
	NM0649-40				
NM0649-50					
⑤ Harness Power Supply	5m NM0414-28	4			
	10m NM0414-33				
⑥ T-harness (R/C-1)	NM0647-09	1			
⑦ T-harness (R/C)	NM0647-10	-	1	2	3
⑧ T-harness (PORT)	NM0647-12	1			
⑨ T-harness (STBD)	NM0647-13	1			
⑩ Push - pull cable	TFXtreme, 33HPC	4			
⑪ Idle Switch (optional)	NJ0765-00	1	2	3	4
⑫ Handheld control (optional)	Refer to handheld control manual				
Circuit Breaker (optional)	20A NJ0514-00	4			
Buzzer (optional)	12V NJ0596-00	1	2	3	4
	24V NJ0515-00				
SW extension harness (optional)	NM0647-08	1	2	3	4
Trim circuit harness (optional)	NJ0772-00	1	2	3	4

Note: Refer to previous page for balloon references and system configuration.

# TRIPLE ENGINE CONFIGURATION

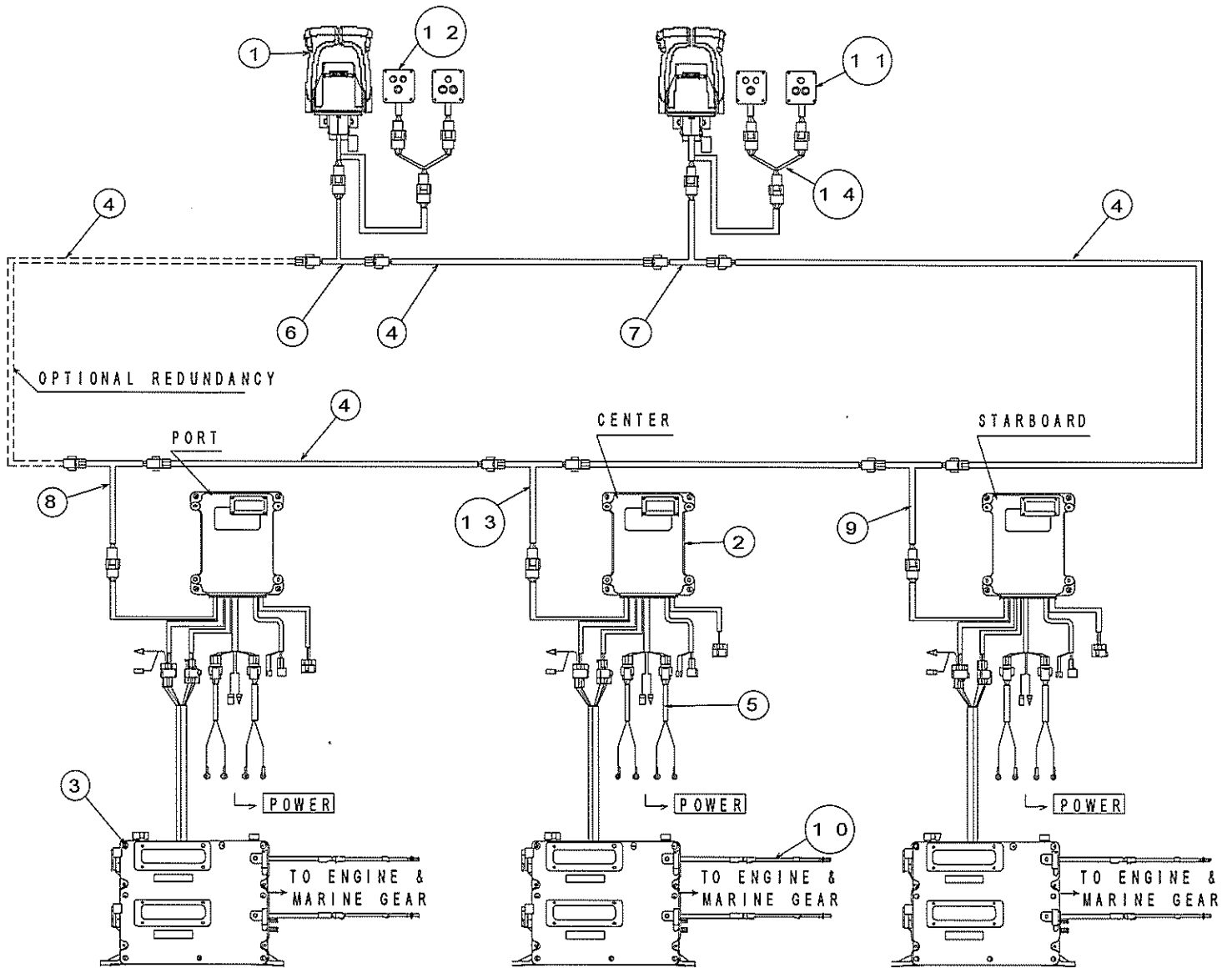

**Note:** The figure above is an example of a three engines / two control stations system with optional idle control switch.

# COMPONENTS LIST

KE-4+ Component Parts List (Triple)		Required Quantity			
		Triple Engine			
		No. of stations			
Description	Part number	1	2	3	4
① Control Head, Twin	w/ PTT NM1051-00				
<i>PTT = power trim/tilt switch (o/b style)</i>	w/o PTT NM1052-00	1	2	3	4
<i>SST = stainless steel, (i/b style)</i>	SST NM1053-00				
② Control unit 12V/24V	NM1475-00	3			
③ Actuator	NM0183-00	3			
④ Bus Harness  1m = 39 inches   CAUTION Bus harness should not exceed 80m in total length; otherwise system performance could degrade.	2m NM0649-02	3	4	5	6
	4m NM0649-04				
	6m NM0649-06				
	8m NM0649-08				
	10m NM0649-10				
	12m NM0649-12				
	14m NM0649-14				
	16m NM0649-16				
	18m NM0649-18				
	20m NM0649-20				
	24m NM0649-24				
	30m NM0649-30				
	40m NM0649-40				
	50m NM0649-50				
⑤ Harness Power Supply	5m NM0414-28 10m NM0414-33	6			
⑥ T-harness (R/C-1)	NM0647-09	1			
⑦ T-harness (R/C)	NM0647-10	-	1	2	3
⑧ T-harness (PORT)	NM0647-12	1			
⑨ T-harness (STBD)	NM0647-13	1			
⑩ Push - pull cable	TFXtreme, 33HPC	6			
⑪ Idle Switch (optional)	NJ0765-00	1	2	3	4
⑫ Triple Switch	NJ0767-00	1	2	3	4
⑬ T-harness (CENTER)	NM0647-14	1			
Circuit Breaker (optional)	20A NJ0514-00	6			
Buzzer (optional)	12V NJ0596-00	1	2	3	4
	24V NJ0515-00				
⑭ SW extension harness (optional)	NM0647-08	1	2	3	4
Trim circuit harness (optional)	NJ0772-00	2	4	6	8

Note: Refer to previous page for balloon references and system configuration.

# QUAD ENGINE CONFIGURATION

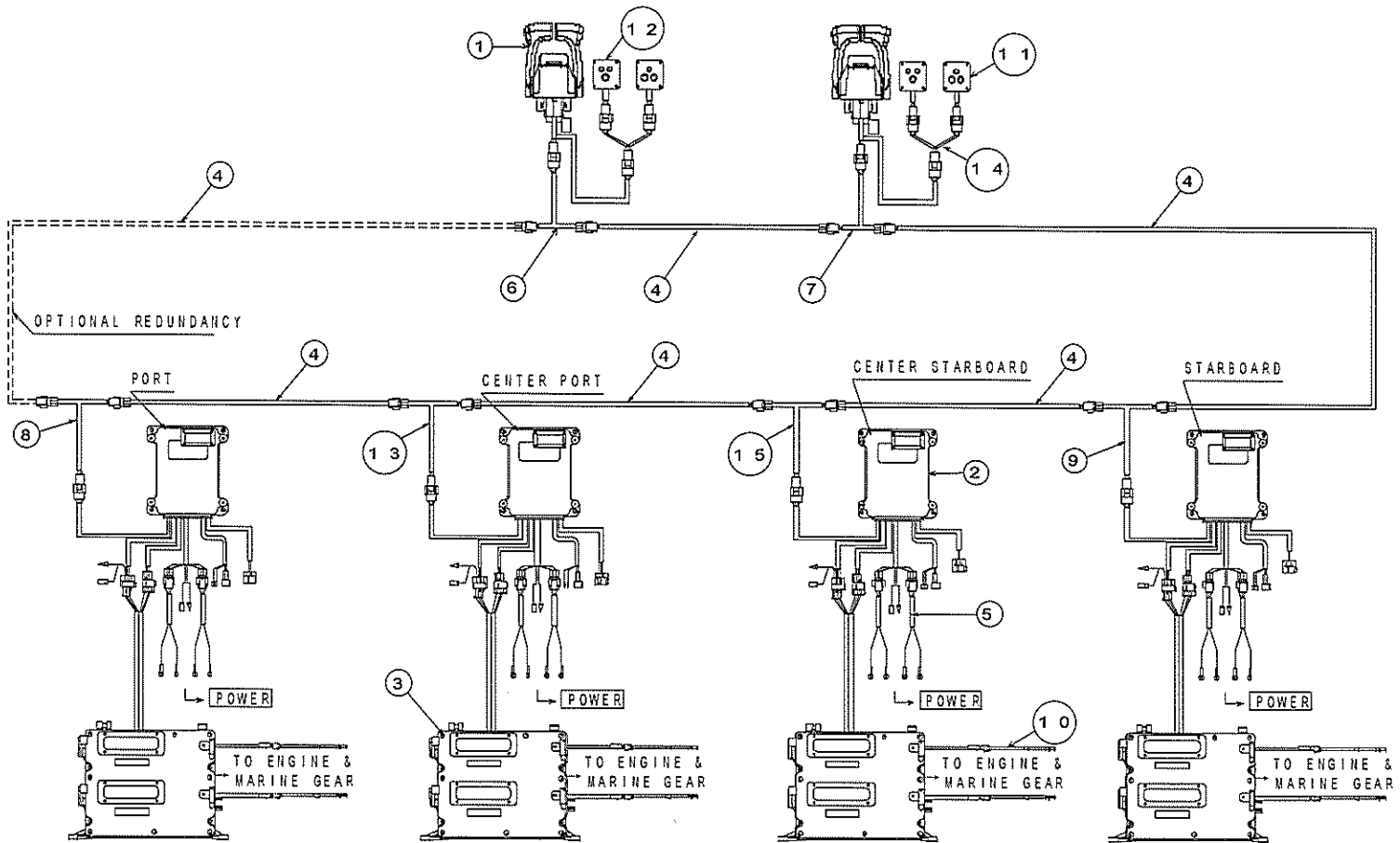

**Note:** The figure above is an example of a four engines / two control stations system with optional idle control switch.

# COMPONENTS LIST

KE-4+ Component Parts List (Quad)			Required Quantity			
			Quad Engine			
			No. of stations			
Description	Part number	1	2	3	4	
① Control Head, Twin	w/ PTT NM1051-00					
<i>PTT = power trim/tilt switch (o/b style)</i>	w/o PTT NM1052-00	1	2	3	4	
<i>SST = stainless steel, (i/b style)</i>	SST NM1053-00					
② Control unit 12V/24V	NM1475-00	4				
③ Actuator	NM0183-00	4				
④ Bus Harness  2m NM0649-02 4m NM0649-04 6m NM0649-06 8m NM0649-08 10m NM0649-10 12m NM0649-12 14m NM0649-14 16m NM0649-16 18m NM0649-18 20m NM0649-20 24m NM0649-24 30m NM0649-30 40m NM0649-40 50m NM0649-50  1m = 39 inches  <div style="text-align: center;">  <b>CAUTION</b>              Bus harness should not exceed 80m in total length; otherwise system performance could degrade.           </div>		4	5	6	7	
	⑤ Harness Power Supply	5m NM0414-28	8			
		10m NM0414-33				
	⑥ T-harness (R/C-1)	NM0647-09	1			
	⑦ T-harness (R/C)	NM0647-10	-	1	2	3
	⑧ T-harness (PORT)	NM0647-12	1			
	⑨ T-harness (STBD)	NM0647-13	1			
	⑩ Push - pull cable	TFXtreme, 33HPC	8			
	⑪ Idle Switch (optional)	NJ0765-00	1	2	3	4
	⑫ Quad Switch	NJ0768-00	1	2	3	4
	⑬ T-harness (CENTER)	NM0647-14	1			
	Circuit Breaker (optional)	20A NJ0514-00	8			
	Buzzer (optional)	12V NJ0596-00	1	2	3	4
		24V NJ0515-00				
⑭ SW extension harness (optional)	NM0647-08	1	2	3	4	
⑮ T-harness (CENTER-STBD)	NM0647-15	1				
Trim circuit harness (optional)	NJ0772-00	2	4	6	8	

Note: Refer to previous page for balloon references and system configuration

# CONTROL UNIT

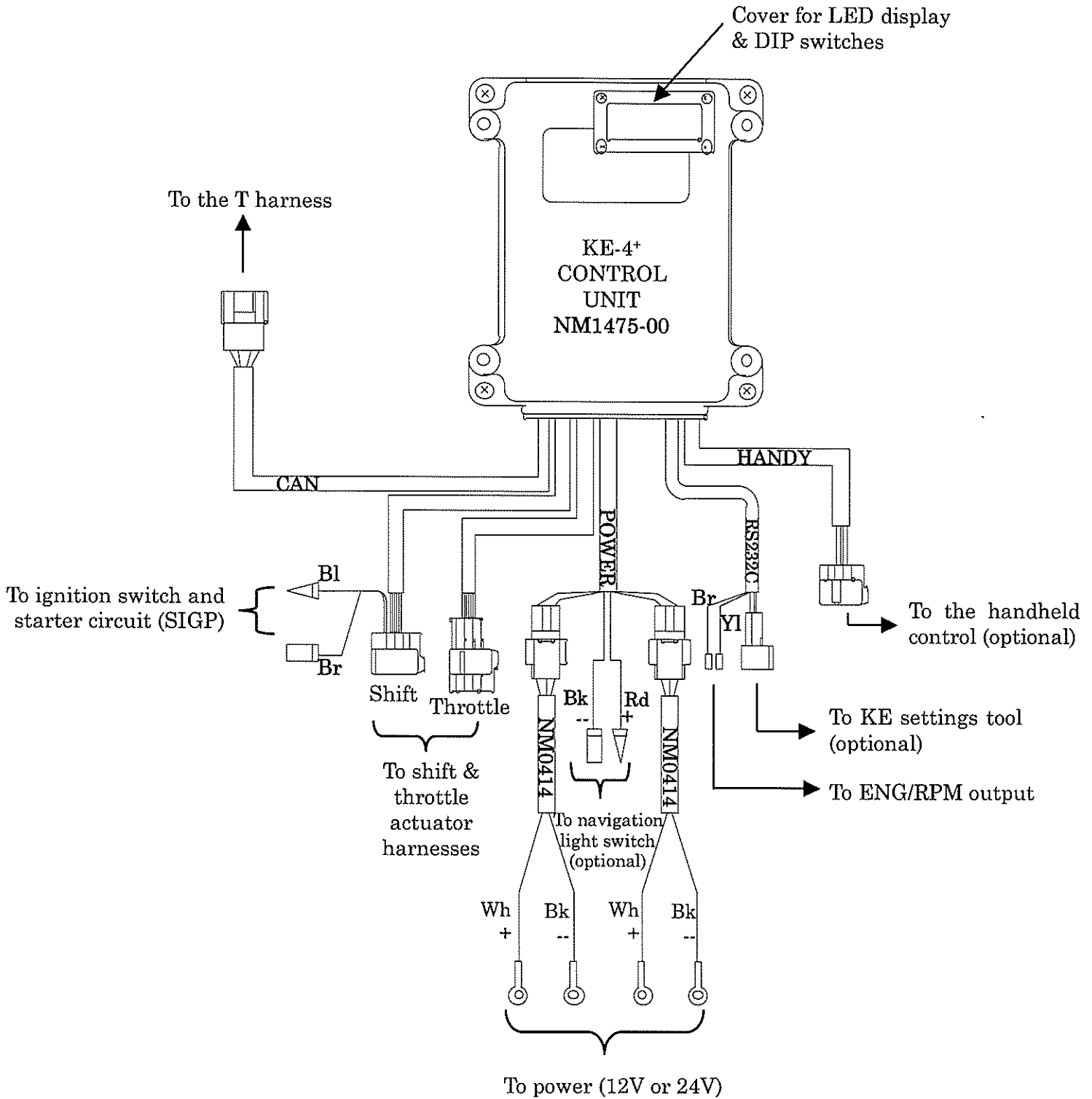

Note: The Control Unit is a common-mode two type that can be used with either 24V or 12V power.

# CONTROL HEAD

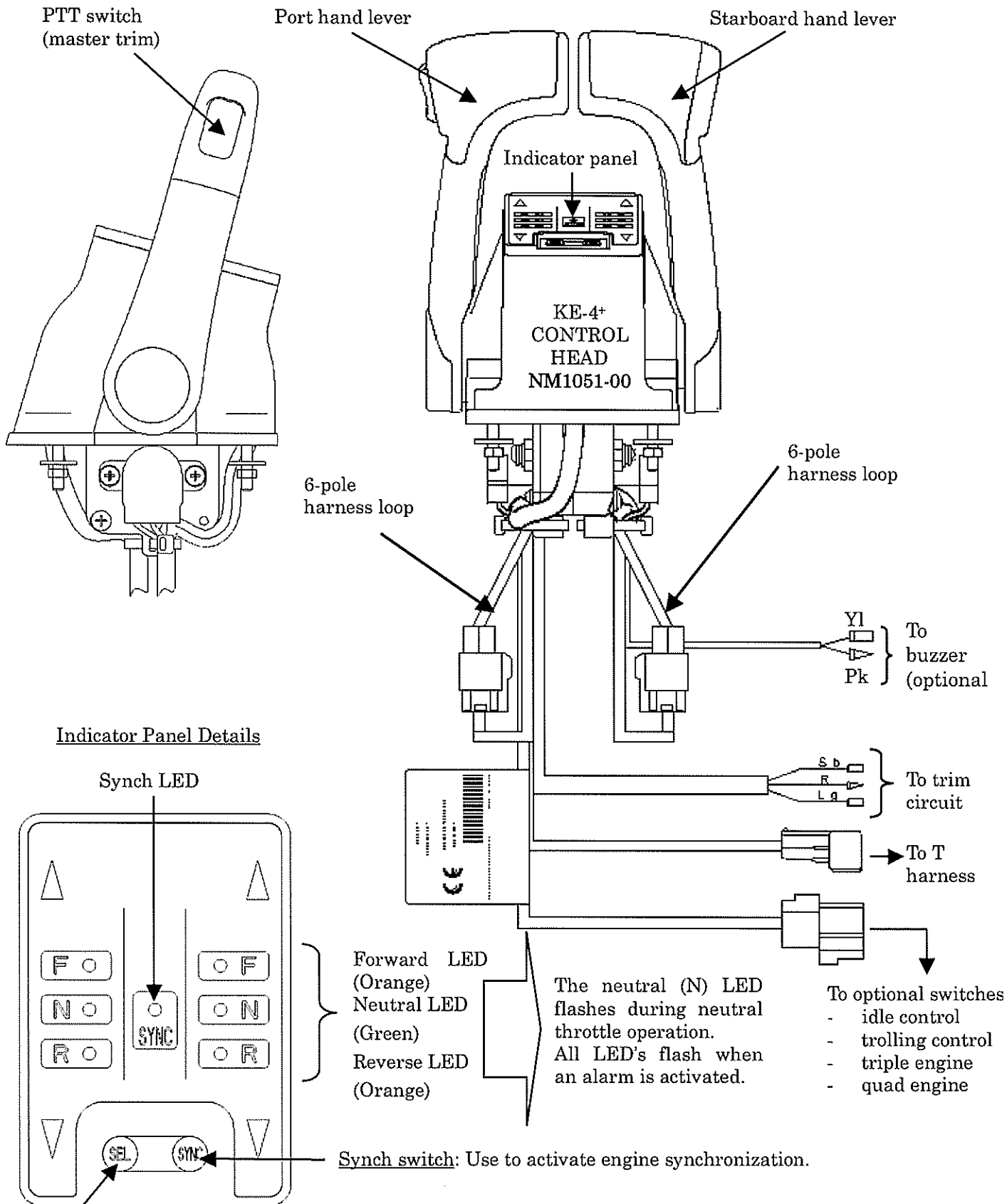

**Select switch:** Press to select station, set/cancel neutral throttle operation, & stop the buzzer.

**Note:** When the power supply is turned ON, the control head connected to R/C-1 T-harness is the first one to become operative. Be sure to connect a control head to R/C-1 T-harness.

# ACTUATOR

 **WARNING**

Operate the Selector Knob only in case of emergency (mechanical backup)

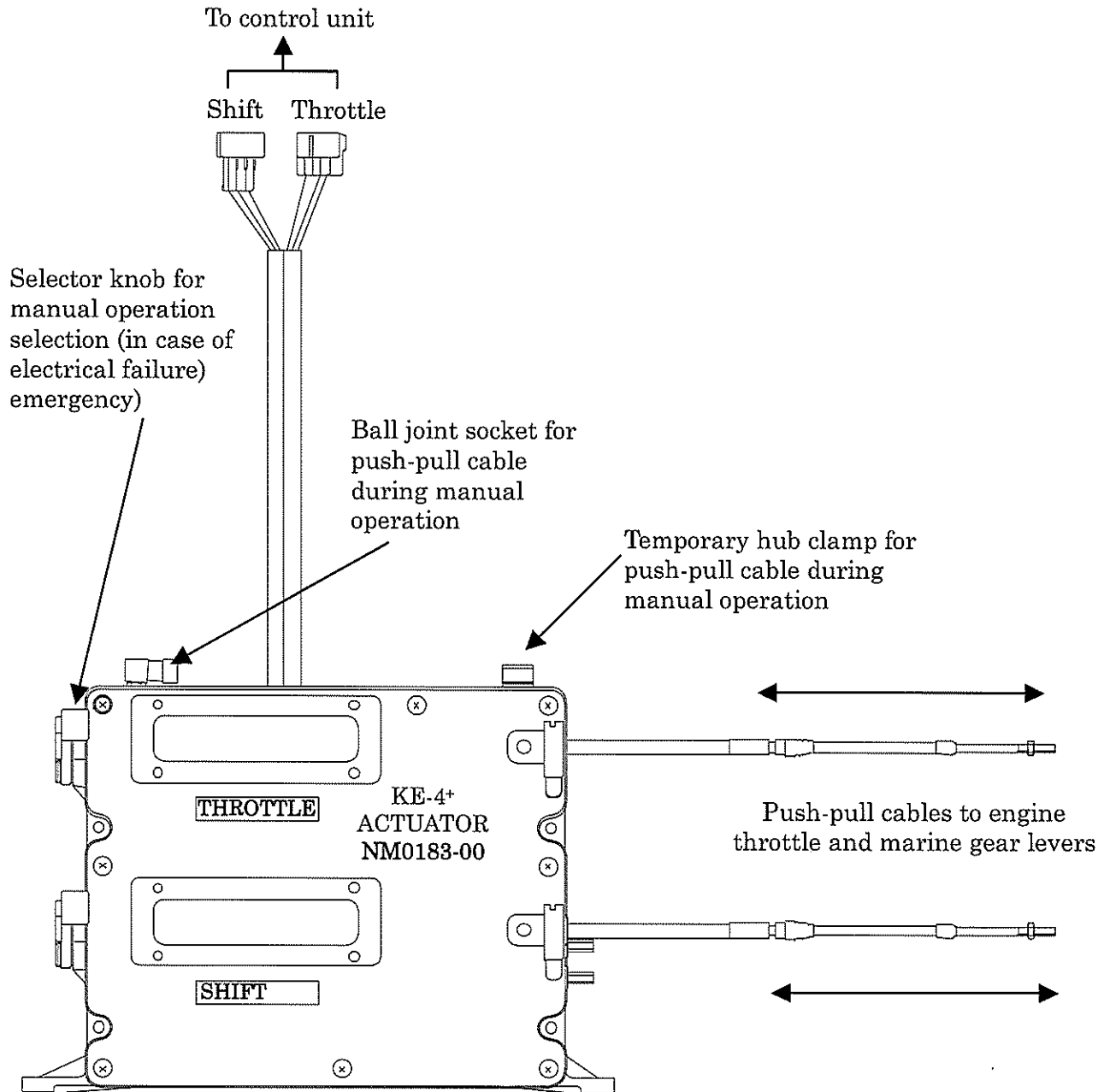

Note: The actuator assembly includes both throttle and shift actuators

---

# KE SYSTEM OPERATION

---

## Initial Control Operation After Power “ ON “

1. With power ON and hand lever in NEUTRAL position, the system is in neutral idle condition.
2. The control head connected to R/C-1 T-harness is considered the master control station and will become operational first. To initiate, perform the following operations:
  - A. Set the handle lever to the “ Neutral “ position.
  - B. Once the green neutral LED(s) is/are ON, system is operational.

Note: If the R/C-1 hand lever(s) are moved to a forward or reverse gear position while power is not applied to the control system and then power is applied, control system will not become operational unit until the hand lever(s) are moved into the NEUTRAL position. The green neutral LED(s) ON status indicate that the control system is operational.

3. When other control stations are required for operation that are connected to R/C T-harness, perform the following actions:
  - A. Set the hand lever to the “ Neutral “ position.
  - B. Press and release the select switch.
  - C. The green neutral LED(s) then lights ON indicating the control is operational.

## Control Head Lever Operation

 CAUTION
---

- |   |
|---|
| <ol style="list-style-type: none"><li>1. Never operate the hand lever while the engine is not running; otherwise actuator, cable, and gear could be damaged.</li><li>2. In the case of a ball joint type connection to engine lever, please regularly inspect the abrasion condition of the joint and apply lubricant grease onto sliding parts. Replace ball joint in case of excessive wear.</li><li>3. Refer to the push-pull cable installation sections for further reference.</li></ol> |
|---|

 WARNING
---

<p><b>DO NOT ATTEMPT</b> sudden forward or reverse motion via hand lever operation. Sudden acceleration/ deceleration may cause damage to the boat or cause operator or passengers to be ejected from the boat.</p>
---

### Control Head Lever Operation (cont'd)

1. Moving the hand lever from the neutral position to the forward or reverse detent causes the actuator to shift to forward or reverse gear. Orange forward or reverse LED(s) light ON to indicate gear position.
2. Moving the hand lever past the forward or reverse detent activates engine throttle operation and the boat will accelerate.

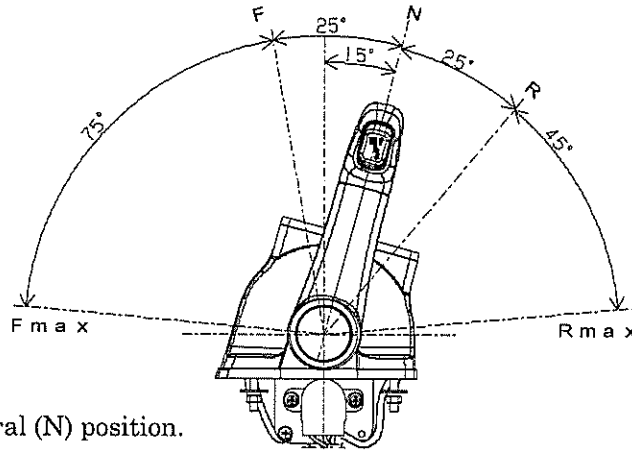

### Neutral Throttle Operation

1. Set the hand lever to the neutral (N) position.
2. Move the hand lever to the forward gear position *while* pressing the station select switch.
3. The green neutral LED flashes and the neutral throttle operation is activated.
4. To deactivate, set the hand lever to the neutral position, press and release the select switch. After the release of the select switch green, neutral LED will stop flashing. This indicates deactivation of the neutral throttle operation.

### Station Transfer for 2, 3 and 4 Station Operation From A Neutral Position

1. Set the hand lever(s) of the selected control to the neutral position, press and release the select switch. A continuous green neutral LED(s) indicates that the control station is active.

### Station Transfer for 2, 3 and 4 Station Operation From A Forward Throttle Position

1. Set the hand lever(s) of the selected control to the neutral position, press and release the select switch. A continuous green neutral LED(s) indicates that the control station is active and the system is in neutral / idle condition.
2. The operator has approximately 4 seconds to move hand levers and match the throttle position of the last active control station. A continuous orange forward LED(s) indicates control station is active and the system is in gear condition.

### Notes:

1. Keeping the hand lever of the selected control station in the neutral position will result in control system automatically returning the control system to a neutral idle condition.

### Synchronization Function

1. Set both hand levers to neutral (N) position.
2. Press SYNC button to activate. A continuous green SYNC LED indicates sync mode.
3. In dual lever mode, synchronization will be automatic whenever the levers are within 10° of each other and in forward mode. In single lever mode, synchronization is automatic with the PORT side lever in forward mode. Refer to 'Adjusting Control Unit' for sync mode setting.
4. To deactivate: set both levers to neutral position and press SYNC button. Green SYNC LED will turn OFF. Note that sync mode will also deactivate if both levers are more than 10° out of alignment in dual lever mode.

---

# DETERMINATION OF CABLE LENGTH

---



## CAUTION

Do not bend the cable to less than the specified radius; otherwise the cable or actuator could be damaged.

### Instructions:

1. Measure the distance from the shift and throttle actuator to the engine's shift and throttle connection location in as straight a line as possible while avoiding any obstruction, which may cause bending below the specified radius. This distance becomes a guideline to determine the actual cable length. For outboard motors, determine the cable length as determined above, then add 1.0 ~ 1.5m (3.3 ft ~ 5 ft) to create a loop shown below.

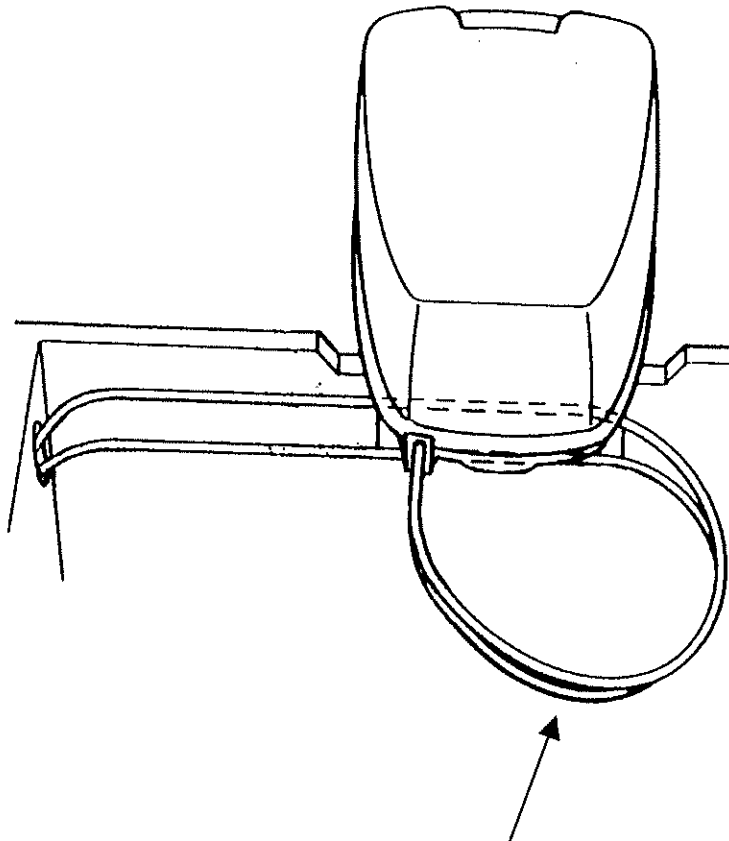

Be aware of push-pull cable bending radius specification.

# INSTALLING THE CONTROL HEAD

## ⚠ WARNING

Install the control head in a location accessible for engine stop at all times.

### Instructions:

1. Select a flat location convenient for installation and operation.
2. Drill mounting hole locations guide by the attached template at the back of the manual.
3. Install with attached washers and nuts.
4. Tighten to 2.9 ~ 4.4 N · m (2.1 ~ 3.2 lbf · ft) of torque.

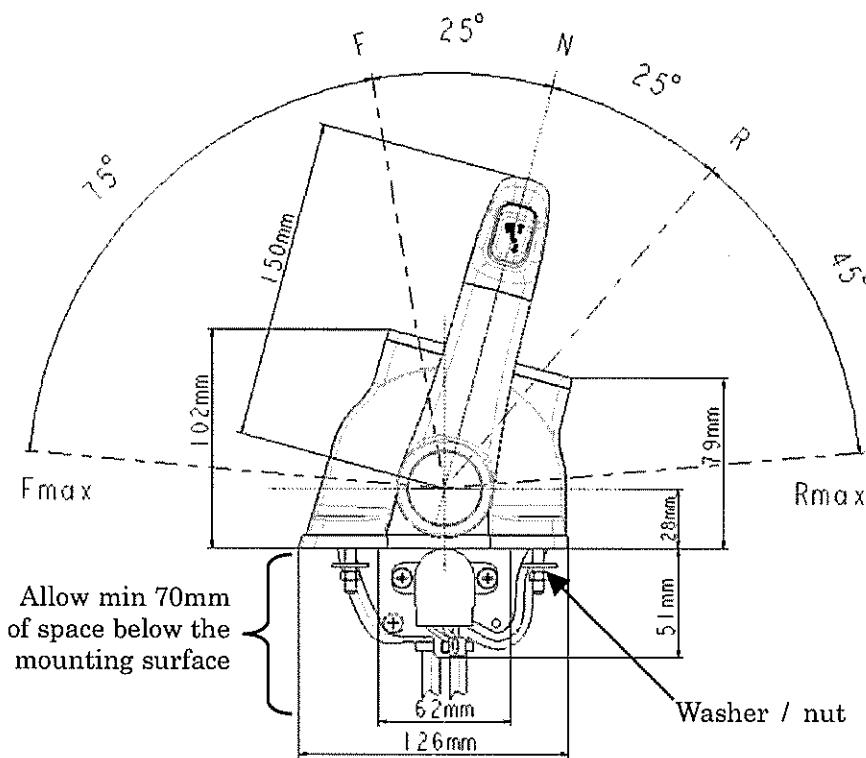

Standard outboard levers shown

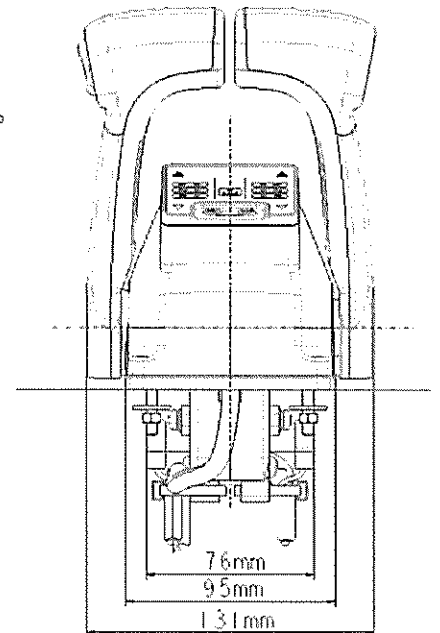

## ⚠ CAUTION

Mount the control head within 60 degrees of horizontal.

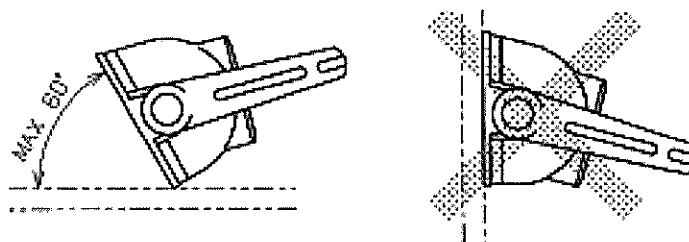

Optional inboard lever shown

# INSTALLING THE CONTROL UNIT



## CAUTION

1. Ingress of water into the unit may cause failure.
2. Install so that harnesses exit through the bottom and the small cover faces up for easy access to DIP switches and viewing of LED indicator.
3. Install in a location where sea wind & water effects are minimized.
4. Avoid a location where the ambient temperature exceeds 75°C.

### Instructions:

1. The actuator harness is 2m (6.5ft) in length. Select the control unit location so that its distance from the actuator is 2m (6.5ft) or less.
2. Drill mounting hole locations guide by the attached template at the back of the manual.
3. Install with included pan head machine screws or tapping screws (see data below)
4. Tighten to 4.9 ~ 7.8 N · m (3.6 ~ 5.7 lbf · ft) of torque.

### Notes:

1. Machine screw mounting plate thickness: 3 ~ 20 mm (1/8 ~ 3/4 in.),  
mounting hole diameter:  $\phi$  7 mm ( $\phi$  1/4 in.).
2. Tapping screw mounting plate thickness: 15 mm min. (5/8 in. min.),  
pilot hole diameter:  $\phi$  3 mm ( $\phi$  1/8 in.).

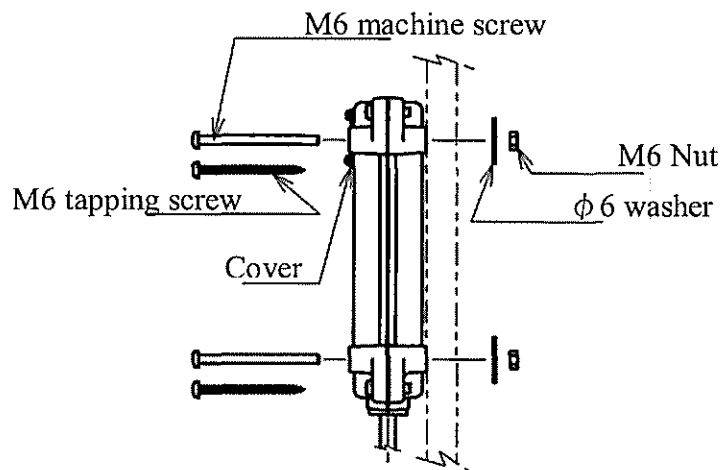

# INSTALLING THE ACTUATOR



## CAUTION

1. Ingress of water into the unit may cause failure.
2. Install in a location convenient for access to manual operation selector knob.
3. Install in a location where sea wind & water effects are minimized.
4. Avoid a location where the ambient temperature exceeds 75°C.

### Instructions:

1. The actuator harness is 2m (6.5ft) in length. Select the actuator location so that its distance from the control unit is 2m (6.5ft) or less.
2. Drill mounting hole locations based on the installation type A (vertical) or B (horizontal) as per the drawings below.
3. Install with included fasteners or with separately purchased machine screws or tapping screw and washer (see data below).
4. Tighten to 3.9 ~ 5.9 N · m (2.9 ~ 4.3 lbf · ft) of torque.

### Notes:

1. Fastener mounting plate thickness : 20mm min. (3/4in. min),
2. Pilot hole diameter :  $\phi$  5mm ( $\phi$  1/5in.)

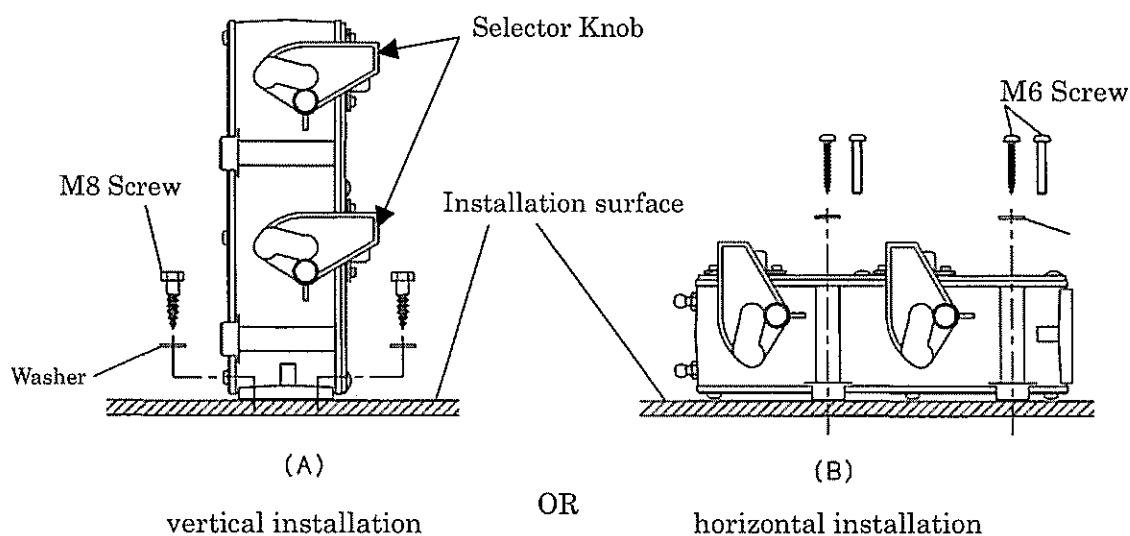

# CONNECTING CONTROL HEAD & CONTROL UNIT

## CAUTION

1. All connectors must be mated firmly; the system may fail to operate otherwise.
2. Be sure to connect a control head to R/C-1. When power is applied, the control head connected to R/C-1 is the first one to become operative.

### Instructions:

1. Connect the 8-pin harness connector of the first control head to the R/C-1 T-harness NM0647-09.
2. Connect the 8-pin harness connector of the remaining control heads to the R/C T-harness(es) NM067-10.
3. Connect the 8-pin harness (CAN) connector of the control units to the appropriate T-harnesses: SINGLE, PORT, STBD, CENTER, CENTER-STBD (NM0647-XX)
4. Finally connect a main bus harness (NM0649-XX) in between each of the T-harness connectors for a continuous data bus between from the first control head to the last control unit.
5. Optional: Add a spare bus harness (NM0649-XX) in between the last 2 ends to close the loop and create a redundant path.

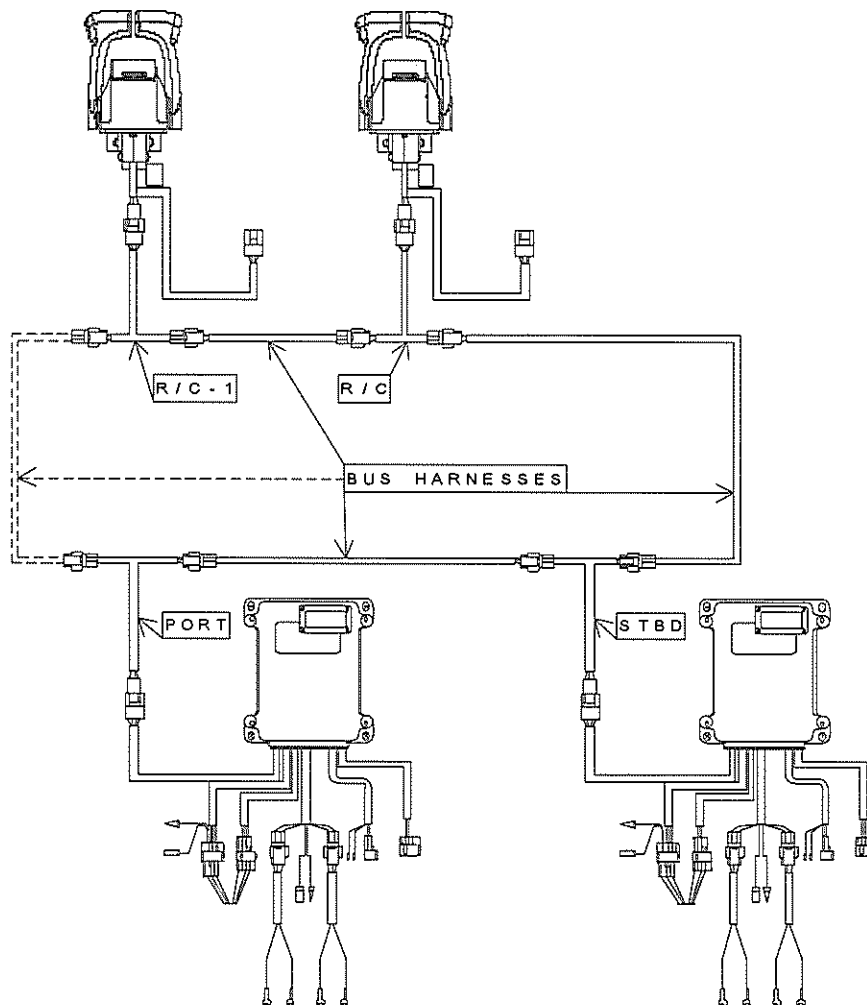

Note: The figure above is an example of a two engines / two control stations system.

# CONNECTING CONTROL UNIT & ACTUATOR

## Instructions:

1. Connect the 12-pin connector and 9-pin connector pair to the actuator harness.

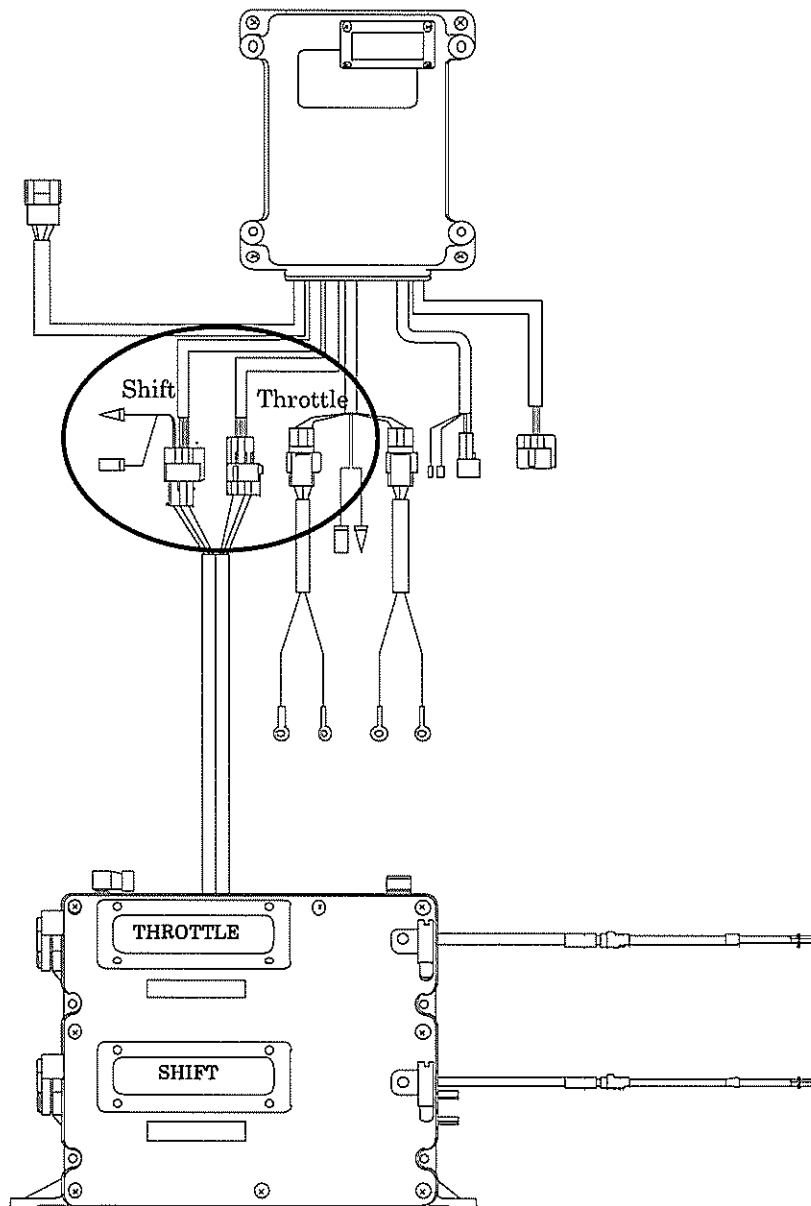

# CONNECTING SIGP: START IN GEAR PROTECTION

## Instructions:

1. Connect between the starter circuit and the ignition switch of the boat.
2. Select extension wires that are as thick (2mm<sup>2</sup> / 14AWG or more) and short as possible; excessively long extensions could cause voltage drop, resulting in failure of engine start.

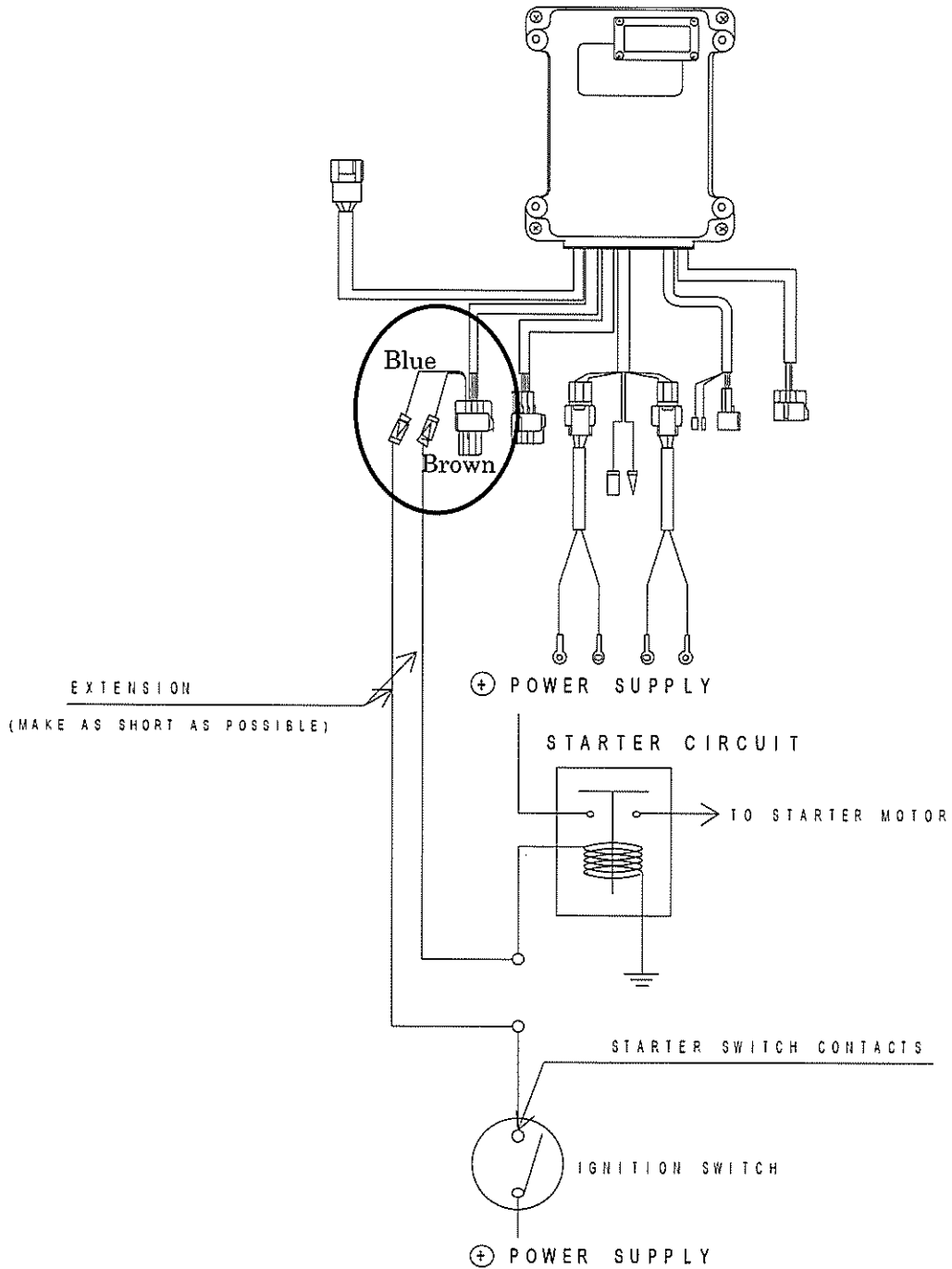

# CONNECTING POWER



## CAUTION

1. As a safety feature, a duplex power line system is provided. Be sure to connect both lines. Alarm code LED's will flash if only one power line is connected.
2. Once the power harness is connected to power (battery), do not attempt to disconnect the power harness from the control unit unless power is first disconnected via circuit breaker or battery switch.

### Instructions:

1. Connect the system power harnesses to the control unit before connecting each power harness to battery (power supply).
2. Connect each black wire of the power harness directly to (- minus) of battery (power).
3. Connect each white wire of the power harness, via the optional 20 amp circuit breaker, via the boat circuit breaker or directly to (+ plus) of battery (power).

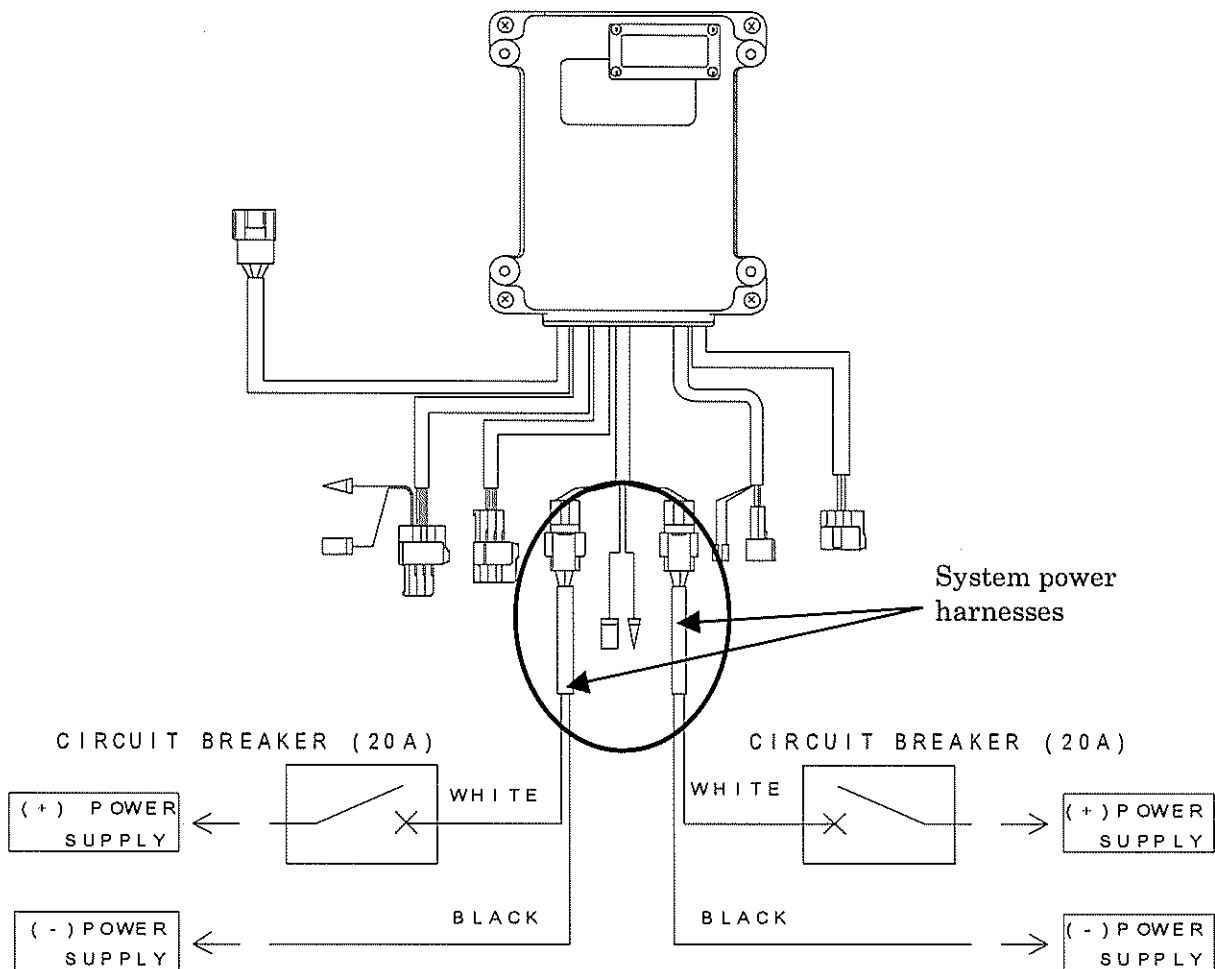

# CONNECTING SYNCHRONIZATION CIRCUIT

Instructions: (in order for the control unit to read engine synch signal properly)

1. Connect the brown wire to the engine rpm (or tachometer) signal in a case of a magnetic pick-up type circuit (typically diesel engine).
2. Connect the yellow wire to the engine rpm (or tachometer) signal in a case of an ignition coil or alternator type circuit (typically gasoline engine).

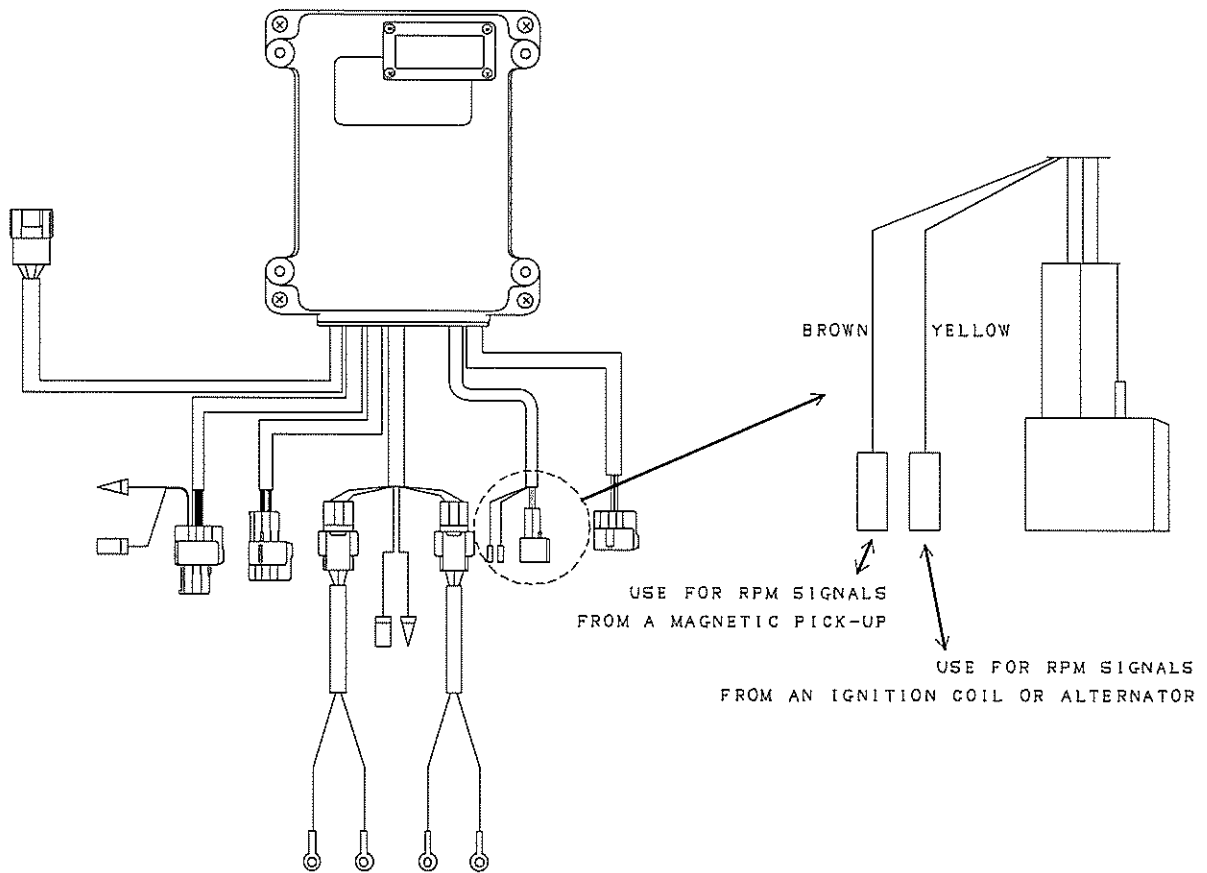

Note: No damage will occur if the case of a wrong connection, synchronization will simply be ineffective.

## CONNECTING DIM HARNESS (OPTION)

### Instructions:

1. Connect the dim harness red wire to the (+) wire of navigation light.
2. Connect the dim harness black wire to the (-) wire of navigation light.

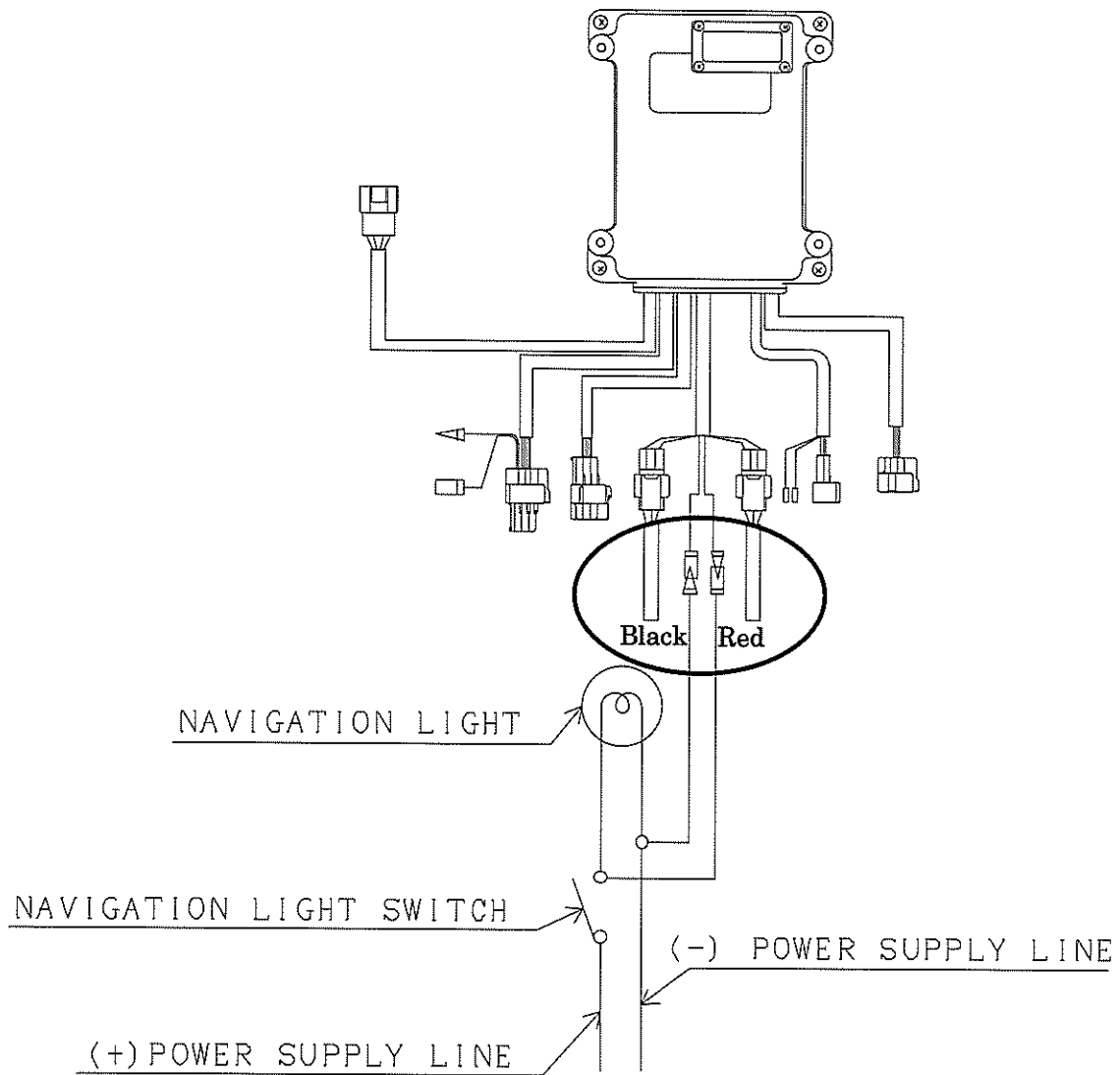

**Note:** Once dim harness is connected, brightness of the control head LED's illumination will be reduced whenever navigation light is ON.

# CONNECTING BUZZER (OPTION)

## CAUTION

Be sure to select the correct buzzer (12V or 24V) for your power source (battery).

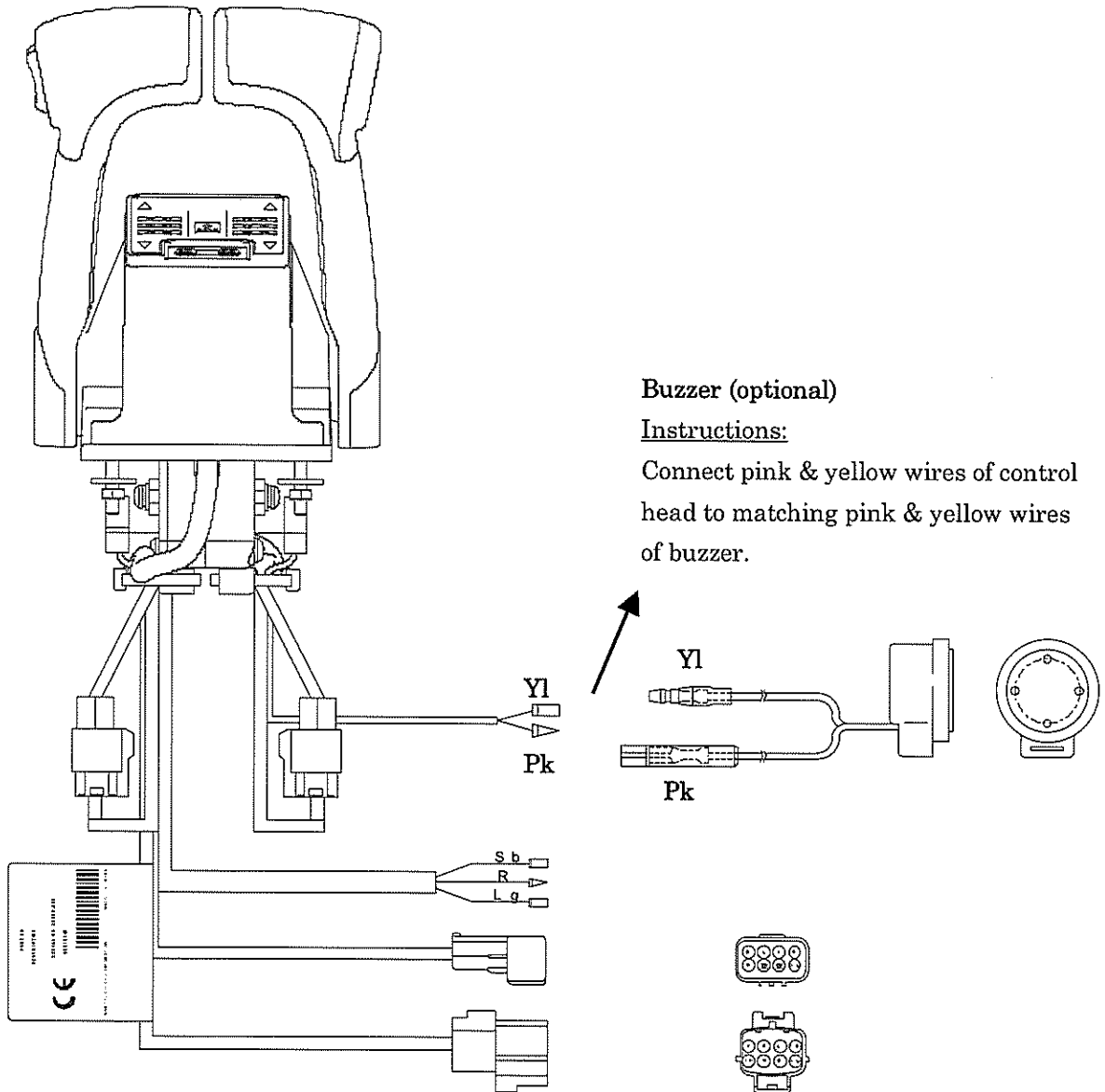

# CONNECTING TRIM CIRCUIT (OPTION)

**Instructions:**

1. Connect the KE-4+ PTT switch (master trim) plus the individual engine trim switches to the switch side of trim circuit harness (included in your PTT kit), as per the circuit below.
2. Connect the other side to the engine connections (engine side), as per the circuit below.

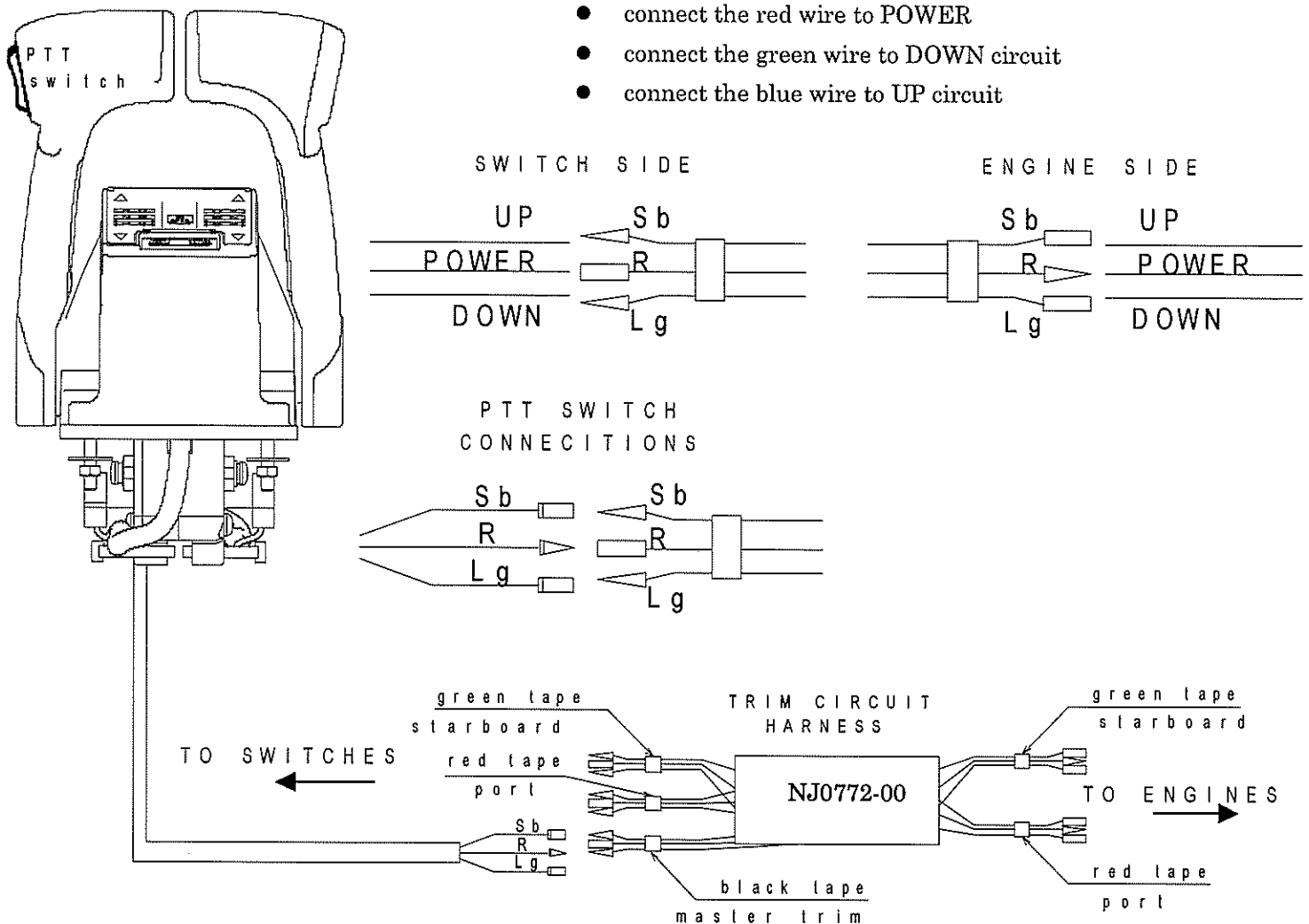

**Notes:**

1. Once connected, the control head PTT switch will provide trim and tilt control of all engines simultaneously.
2. Individual trim switch operation will be possible via the engine trim (panel) switches

# CONNECTING IDLE SWITCH (OPTION)

**Instructions:** For each control head / idle switch pair, connect the 8 pin harness of the control head to the idle switch directly or via a switch extension harness if other optional switches are also part of the main KE-4+ system.

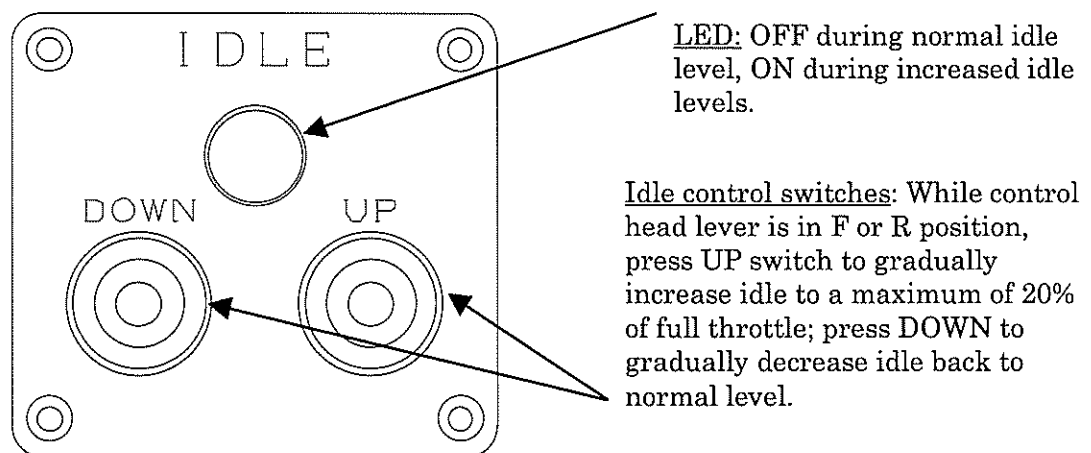
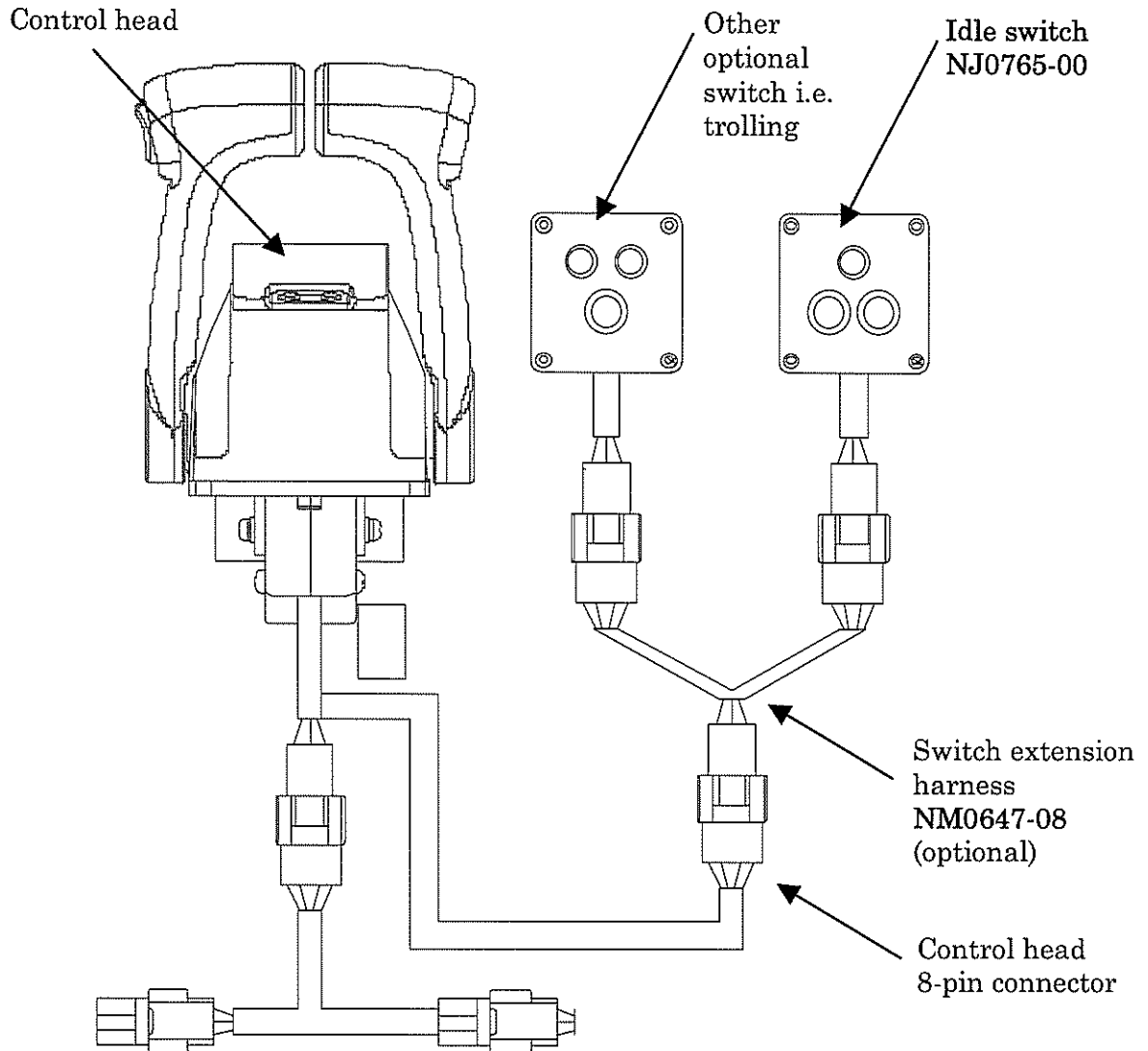

# CONNECTING TRIPLE SWITCH (OPTION)

**Instructions:** For each control head / triple switch pair, connect the 8 pin harness of the control head to the trolling switch directly or via a switch extension harness if other optional switches are also part of the main KE-4+ system.

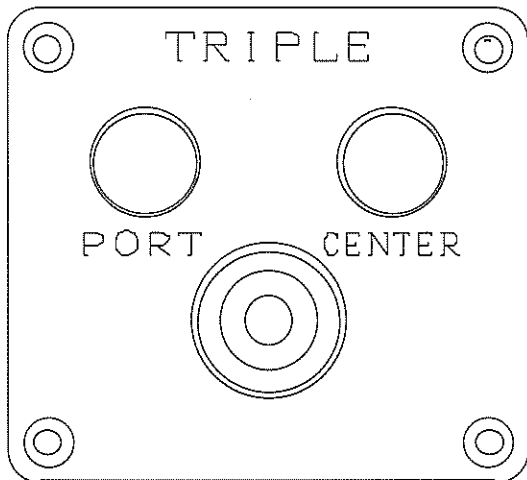
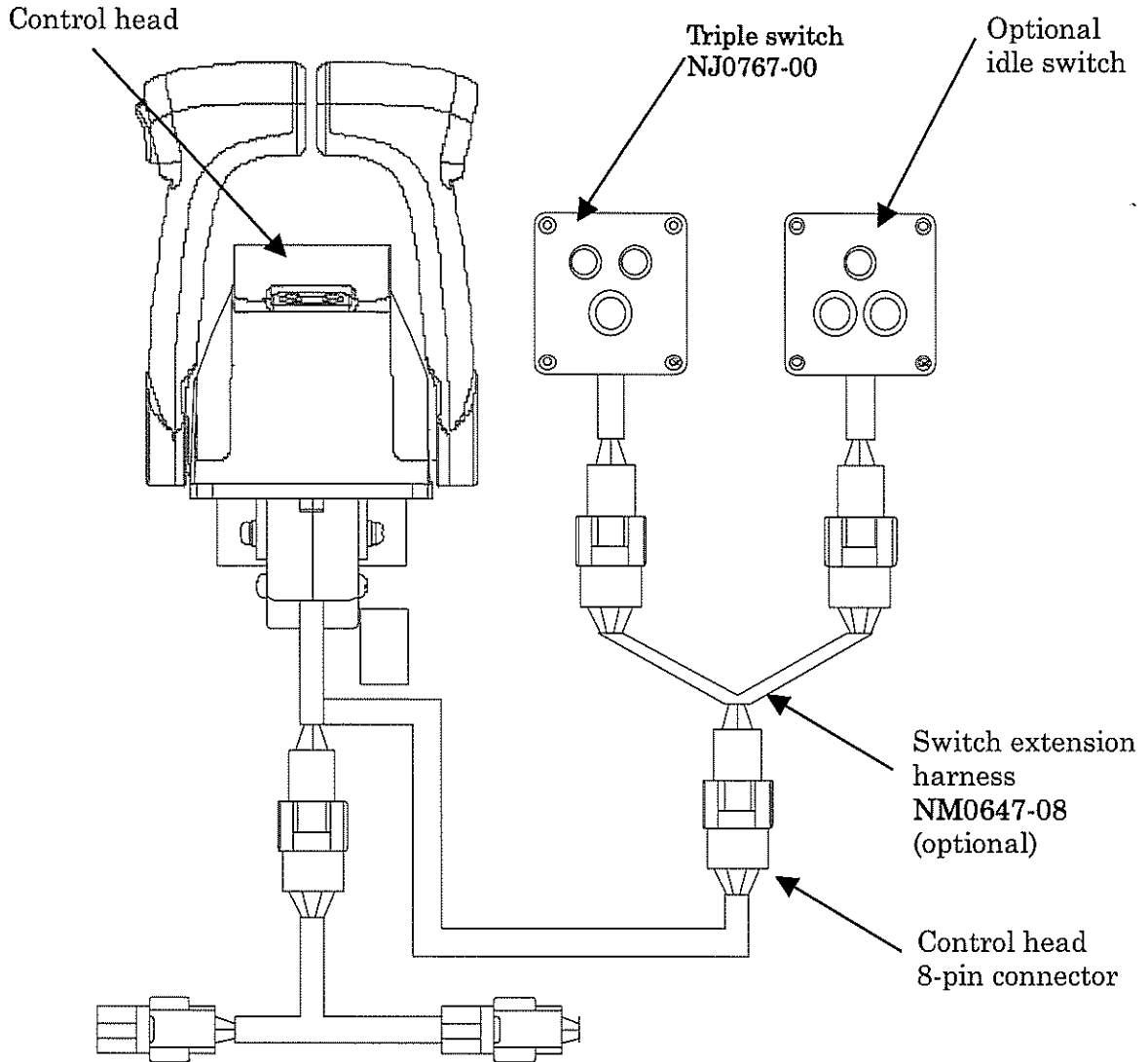

SWITCH STATUS	PORT LED	CENTER LED	PORT LEVER CONTROL
POWER ON	ON	ON	port & center actuators
PUSH 1	ON	OFF	port actuator
PUSH 2	OFF	ON	center actuator
PUSH 3	ON	ON	port & center actuators

# CONNECTING QUAD SWITCH (OPTION)

**Instructions:** For each control head / quad switch pair, connect the 8 pin harness of the control head to the trolling switch directly or via a switch extension harness if other optional switches are also part of the main KE-4+ system.

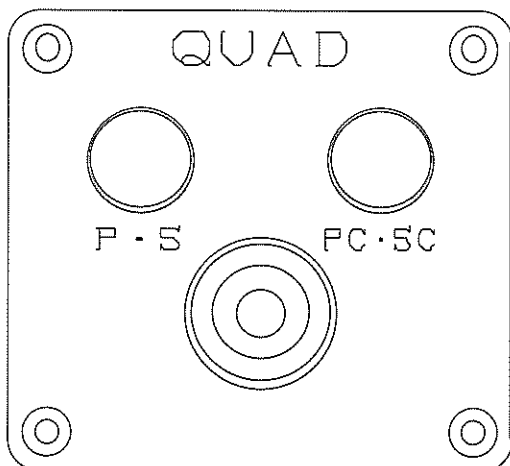
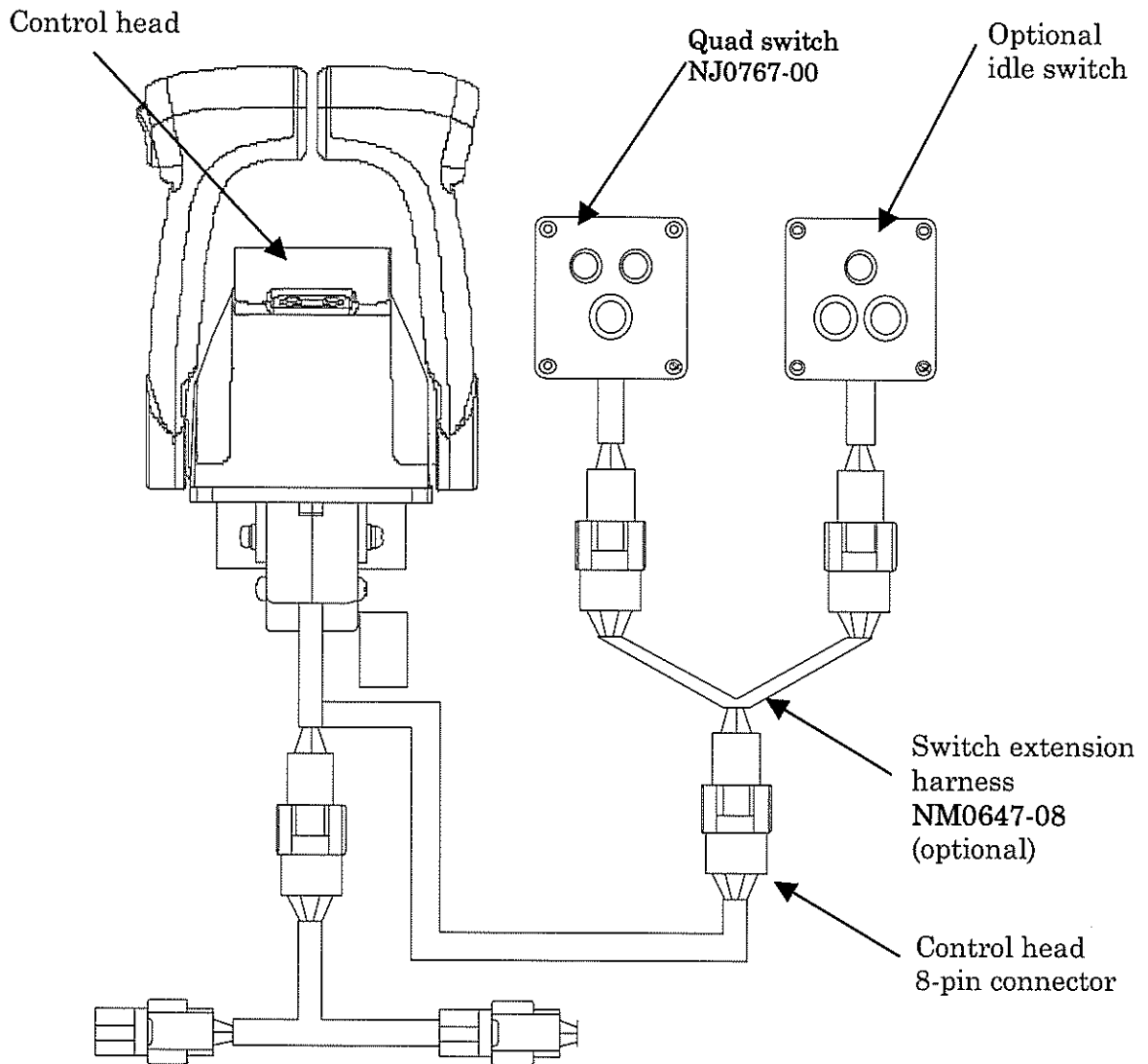

SWITCH STATUS	P·S LED	PC·SC LED	LEVERS CONTROL
POWER ON	ON	ON	all 4 actuators
PUSH 1	ON	OFF	outside actuators
PUSH 2	OFF	ON	inside actuators
PUSH 3	ON	ON	all 4 actuators

# PUSH-PULL CABLE INSTALLATION

Instructions: → push-pull cables to actuator

1. Install the rod end to the rod and set with lock nut.
2. Tighten to  $2.9 \sim 4.4 \text{ N} \cdot \text{m}$  ( $2.1 \sim 3.2 \text{ lbf} \cdot \text{ft}$ )
3. Remove the eight (8) actuator screws shown with arrows and remove the cover
4. Install the waterproof grommet around the cable.
5. Install the rod end, hub and waterproof grommet to the actuator mount groove as shown below.
6. Re-install the cover onto the actuator with screws.
7. Tighten to  $1.2 \sim 1.8 \text{ N} \cdot \text{m}$  ( $0.9 \sim 1.3 \text{ lbf} \cdot \text{ft}$ )

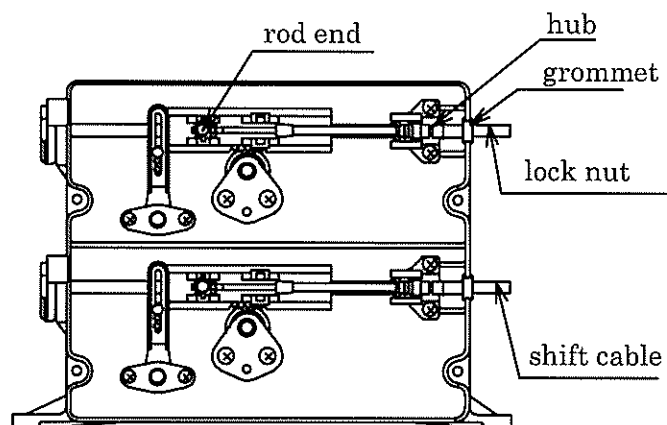
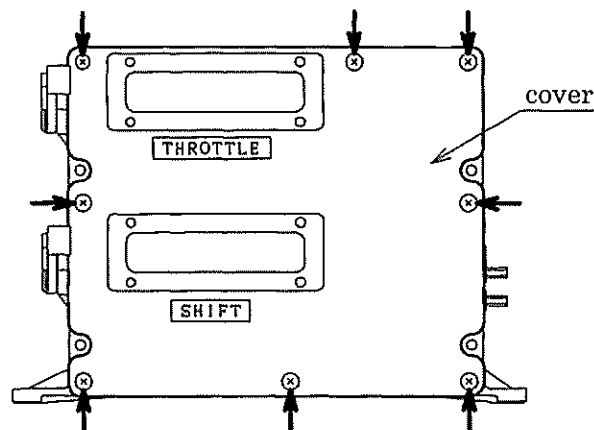
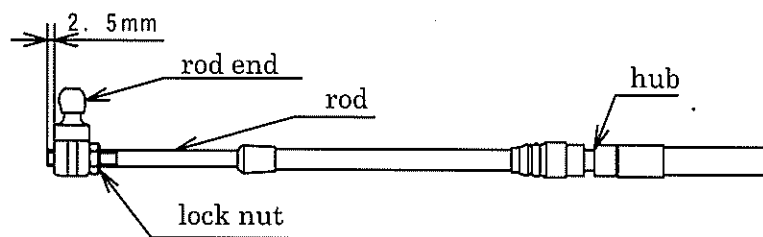

---

# PUSH-PULL CABLE INSTALLATION

## (continued)

---



### CAUTION

1. Be sure to completely install the push-pull cables in the actuator before installing the other ends to the engine & gear.
2. Also turn OFF power supply to the control unit before installing the push-pull cables to the engine & gear.
3. Install the cables onto the engine as per the engine manual.
4. Please make sure that the system is installed such that the push-pull cable motions correspond properly with the engine and gearbox mode of operation (i.e. stroke direction and distance); otherwise damage could occur.

#### Instructions: → Initialization

8. Turn power ON to the KE system control unit.
9. Set the R/C-1 control head lever(s) to neutral position.
10. The throttle actuator should now be fully closed and the shift actuator should be in neutral position.
11. Positioning is completed once the neutral lamp goes ON. Push-pull cables are now ready for installation to engine & marine gear as per engine manual.

# ADJUSTING THE CONTROL UNIT

## ⚠ CAUTION

1. Be sure to turn OFF the power to the control unit before removing the push-pull cables from the engine / gear.
2. Once control unit adjustment is completed, re-install the cover for proper seal, torque to 1.0 ~ 1.7 N·m (0.7 ~ 1.2 lbf·ft). Then, carry out positioning of the actuator (see previous page).

**Instructions:** To adjust system settings compatibility with engine and gear, remove the control unit small cover (4 screws) and modify the DIP switch configurations, based on the tables below.

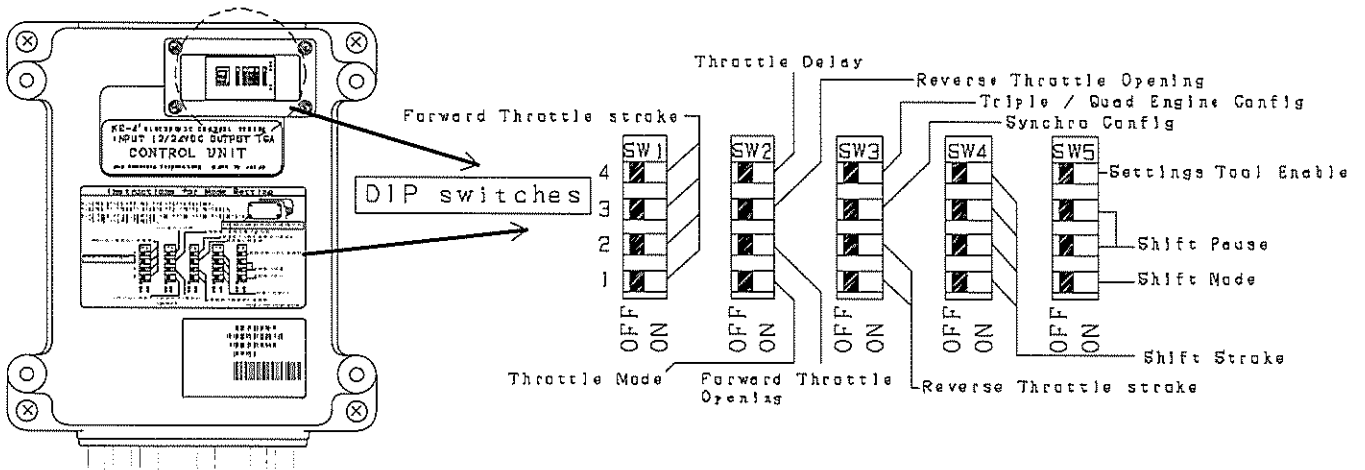

### Shift mode.

Select the following DIP switch configurations for the desired shift push-pull cable direction setting.

SW5-1	FUNCTION
OFF	Pull to go forward
ON	Push to go forward

\*Before shipment, all switches are set to OFF (pull to go forward).

### Shift stroke: Forward

Select the following DIP switch configurations for the desired forward shift stroke setting.

SW4-1	SW4-2	STROKE
ON	OFF	26mm (1.0 in)
OFF	ON	30mm (1.2 in)
OFF	OFF	34mm (1.3 in)
ON	ON	40mm (1.5 in)

\*Before shipment, all switches are set to OFF (34mm).

### Shift stroke: Reverse

Select the following DIP switch configurations for the desired reverse shift stroke setting.

SW4-3	SW4-4	STROKE
ON	OFF	26mm (1.0 in)
OFF	ON	30mm (1.2 in)
OFF	OFF	34mm (1.3 in)
ON	ON	40mm (1.5 in)

\*Before shipment, all switches are set to OFF (34mm).

### Throttle mode

Select the following DIP switch configurations for the desired throttle push-pull cable direction setting.

SW 2-1	FUNCTION
OFF	Pull to open throttle
ON	Push to open throttle

\*Before shipment, all switches are set to OFF (pull to open).

### Forward throttle stroke

Select the following DIP switch configurations for the desired throttle stroke settings. When the hand lever is operated from forward to full forward, the throttle actuator stroke can be set from 31mm to 73mm via 3mm intervals, plus a 80mm setting.

SW1-1	SW1-2	SW1-3	SW1-4	STROKE
ON	OFF	ON	ON	31mm (1.2 in)
ON	OFF	OFF	ON	34mm (1.3 in)
ON	OFF	ON	OFF	37mm (1.45 in)
ON	OFF	OFF	OFF	40mm (1.6 in)
OFF	ON	ON	ON	43mm (1.7 in)
OFF	ON	OFF	ON	46mm (1.8 in)
OFF	ON	ON	OFF	49mm (1.9 in)
OFF	ON	OFF	OFF	52mm (2.0 in)
OFF	OFF	ON	ON	55mm (2.2 in)
OFF	OFF	OFF	ON	58mm (2.3 in)
OFF	OFF	ON	OFF	61mm (2.4 in)
OFF	OFF	OFF	OFF	64mm (2.5 in)
ON	ON	ON	ON	67mm (2.6 in)
ON	ON	OFF	ON	70mm (2.75 in)
ON	ON	ON	OFF	73mm (2.9 in)
ON	ON	OFF	OFF	80mm (3.15 in)

\*Before shipment, all switches are set to OFF (64mm).

**Reverse throttle stroke.**

Select the following DIP switch configurations for the desired reverse throttle setting.

SW 3-1	SW 3-2	FUNCTION
OFF	OFF	60% of the forward full open stroke
ON	OFF	80% of the forward full open stroke
OFF	ON	100% of the forward full open stroke
ON	ON	100% of the forward full open stroke

\*Before shipment, all switches are set to OFF (60% of forward)

**Synchronization configuration**

Select the following DIP switch configurations for the desired synchronization setting.

SW 3-3	FUNCTION
OFF	Single lever controls both engine actuators during synchronization.
ON	Dual lever control

\*Before shipment, all switches are set to OFF (single lever).

Notes:

1. Be sure to set the DIP switches of both control units for proper synchronization function.
2. Refer to previous sections in this manual for synch function connection & operation instructions.

**Forward throttle opening.**

Select the following DIP switch configurations for the desired forward throttle opening curve. This function facilitates fine throttle adjustment over the idle to low RPM range and decreases the shock effect if the hand lever is operated suddenly.

SW 2-2	FUNCTION
OFF	Forward throttle linear
ON	Forward throttle non-linear

\*Before shipment, all switches are set to OFF (opening 1)

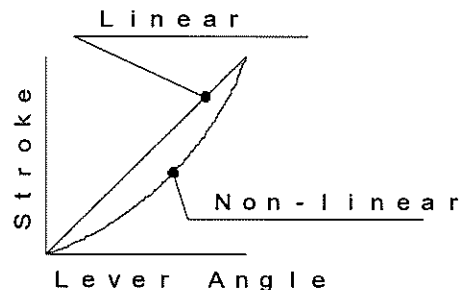

**Reverse throttle opening.**

Select the following DIP switch configurations for the desired reverse throttle opening curve.

SW2-3	FUNCTION
OFF	Reverse throttle non-linear A
ON	Reverse throttle non-linear B

\*Before shipment, all switches are set to OFF (opening 1)

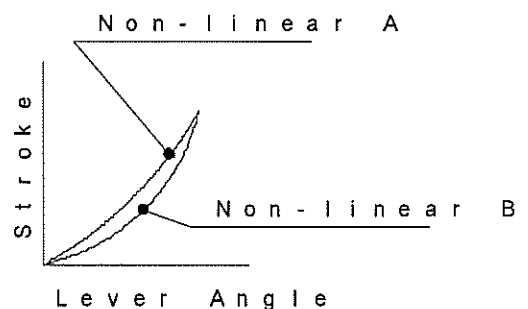

### Throttle delay.

Select the following DIP switch configurations for the desired throttle delay setting. This function delays the shock effect if the hand lever is operated suddenly from neutral to throttle.

SW 2-4	FUNCTION
OFF	No throttle delay
ON	Throttle delay active.

\*Before shipment, all switches are set to OFF (no delay).

### Shift pause.

Select the following DIP switch configurations for the desired shift pause setting. This function delays the shock effect if the hand lever is operated suddenly from throttle to neutral.

SW 5-2	SW 5-3	FUNCTION
OFF	OFF	No shift pause
OFF	ON	2 seconds
ON	OFF	4 seconds
ON	ON	6 seconds

\*Before shipment, all switches are set to OFF (no pause)

### Triple & Quad engine configuration (not active for single or dual engine configuration)

Select the following DIP switch configurations for the desired triple & quad engine settings.

SW 3-4	FUNCTION
OFF	When outside engine control head lever positions do not match (i.e. PORT Forward, STBD Reverse) then inside engine actuator(s) default to Neutral. When control head lever positions match, inside actuator(s) also match.
ON	Triple: Center engine actuator follows PORT actuator operation. Quad: Inside engine actuators follow adjacent outside actuator operation.

\*Before shipment, all switches are set to OFF (Center engine neutral default).

### Settings tool enable (intended for multi-vessel data management, requires PC connection)

Select the following DIP switch configurations for the desired settings tool setting.

SW 5-4	FUNCTION
OFF	Settings tool & system log access inactivated
ON	Settings tool & system log access activated.

\*Before shipment, all switches are set to OFF (inactive)

Note: This DIP switch is intended to activate a software-controlled version of the settings configuration. It is intended for multi-vessel data management (boat builders, distributors, etc.) and requires a PC connection via a custom cable.

# OPERATION CHECK

**Instructions:** Once installation is completed, carry out the following operation check:

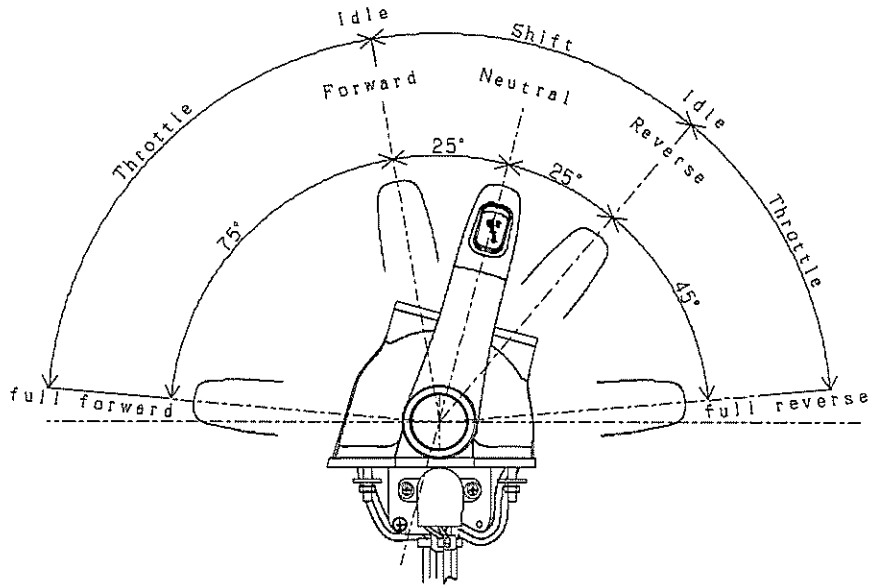

## CAUTION

1. Never operate the hand lever while the engine is not running; otherwise, the actuator, push-pull cable, or engine / marine gear may be damaged.
2. Please make sure that the system is installed such that the push-pull cable motions correspond properly with the engine and gearbox mode of operation (i.e. stroke direction and distance); otherwise damage could occur.

### Shift and throttle operation check

Step	Hand lever operation	Action
1	Neutral → Forward	Shift actuator from neutral to forward
2	Forward → Forward full open	Throttle actuator fully closed to fully open
3	Forward full open → Neutral	Throttle actuator fully open to fully closed Shift actuator from forward to neutral
4	Neutral → Reverse	Shift actuator from neutral to reverse
5	Reverse → Reverse full open	Throttle actuator fully closed to fully open.
6	Reverse full open → Neutral	Throttle actuator from fully open to fully closed Shift actuator from reverse to neutral

**Note:** If the correct operation cannot be made, change the operation mode. (See "Adjusting the Control Unit"). If the forward/neutral/reverse LED's flash, refer to "Alarm Codes".

### Confirmation of the engine start

Step	Description	OK	NG -> Countermeasure
1	Set hand lever to NEUTRAL and start the engine	Engine starts	Shorten SIGP wiring connection (page 23)
2	Set hand lever to FORWARD and start the engine	Engine does not start	Connect SIGP as per instructions (page 23)

# MANUAL OPERATION METHOD (OPTION)



## WARNING

Attempt manual operation only in cases of emergency.  
Use for immediate return to shore

Note: This feature is intended for use when there is a failure to the electrical system.

### Instructions:

1. Install the mechanical control head and push-pull cable according to the instruction manual of the optional mechanical control head.
2. Install ball joint socket to the output end of the push-pull cable and fix it to the actuator.
3. Remove the black cover and expose the ball stud.
4. Tilt the selector knob fully in the arrow direction.
5. Remove the cable from the position and install its ball joint socket onto the ball stud and the hub onto the clamp.
6. The actuator can then be operated manually via the mechanical control head levers.
7. Return the selector knob to the original position after manual operation is no longer necessary.

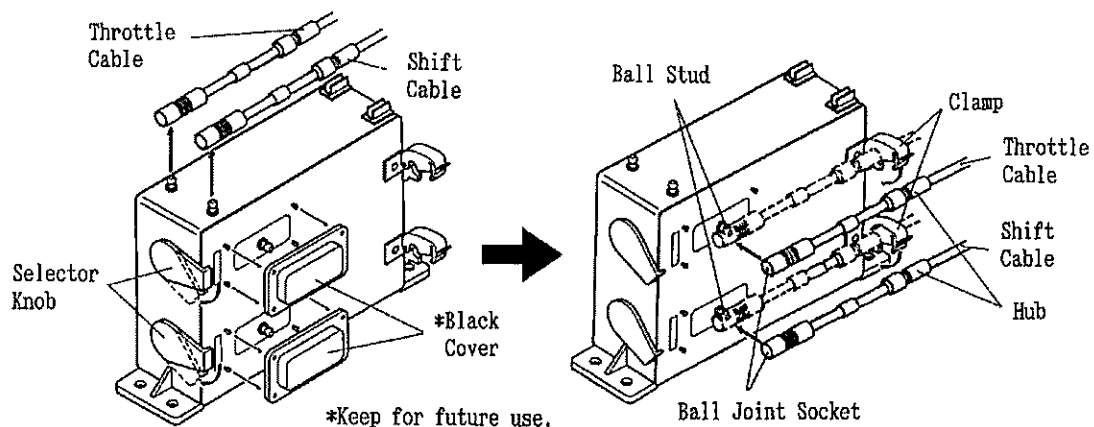
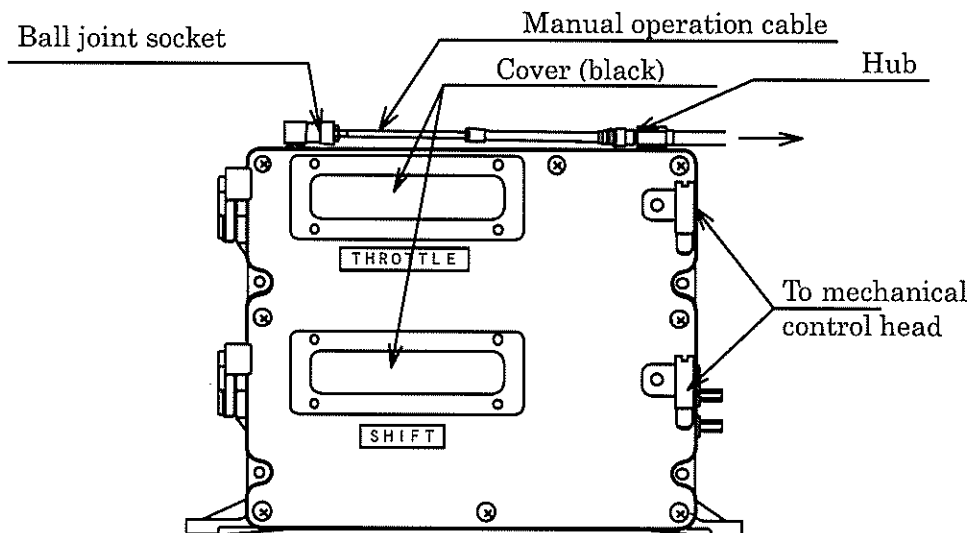

# ALARM CODES

In case of a system operation fault, the failure code is indicated via the forward/neutral/reverse LED's flashing frequency plus the alphanumeric LED display on the control unit and an optional buzzer.

LED Flashing Frequency	Possible Cause	Check / Countermeasure	Reference
1 * Shift Actuator Signal	<p>①Shift actuator and control unit not connected properly.</p> <p>②A. Shift actuator harness: 1 output line damaged / shorted -&gt; system still operates</p> <p>②B. Shift actuator harness: 2 output lines damaged/short -&gt; system no longer operates</p> <p>③Shift actuator set to manual operation.</p>	<p>①Reconnect the shift actuator to control unit.</p> <p>②A. Consult dealer for replacement item at earliest convenience.</p> <p>②B. Consult dealer for replacement item immediately.</p> <p>③Set system to NEUTRAL and rotate selector knob to electronic operation.</p>	<p>Page 22</p> <p>Page 39</p>
2 ** Throttle Actuator Signal	<p>①Throttle actuator and control unit not connected properly.</p> <p>②A. Throttle actuator harness 1 output line damaged -&gt; system still operates</p> <p>②B. Throttle actuator harness: 2 output lines damaged -&gt; system no longer operates</p> <p>③Throttle actuator set to manual operation.</p>	<p>①Reconnect the throttle actuator to control unit.</p> <p>②A. Consult dealer for replacement item at earliest convenience.</p> <p>②B. Consult dealer for replacement item immediately.</p> <p>③Set system to neutral and rotate selector knob to electronic operation.</p>	<p>Page 22</p> <p>Page 39</p>
3 *** Control Head	<p>①Control head 6-pole harness loop not properly connected.</p> <p>②A. Control head 6-pole harness loop : 1 output line damaged → system still operates.</p> <p>②B. Control head 6-pole harness loop : 2 output lines damaged → system no longer operates.</p>	<p>①Reconnect 6-pole harness loop(s).</p> <p>②A. Consult dealer for replacement item at earliest convenience.</p> <p>②B. Consult dealer for replacement item immediately.</p>	<p>Page 13</p> <p>Page 13</p>
4 **** Shift Actuator	<p>①Push-pull cable installed without proper positioning.</p> <p>②Shift actuator stroke exceeding stroke of the gear clutch.</p> <p>③Shift actuator set to manual operation.</p> <p>④Loose push-pull cable.</p> <p>⑤Loose clutch connection or clutch load too heavy for shift actuator.</p> <p>⑥No motor motion</p>	<p>①Perform proper cable positioning &amp; initialization of the shift actuator.</p> <p>②Reduce shift actuator stroke.</p> <p>③Set system to NEUTRAL and rotate selector knob to electronic operation.</p> <p>④Fasten cable rod end, lock nuts.</p> <p>⑤Verify clutch connection or clutch load (particularly outboard motor dog clutch).</p> <p>⑥Consult dealer for replacement item.</p>	<p>Page 33</p> <p>Page 34</p> <p>Page 39</p> <p>Page 32, 39</p>

## ALARM CODES (continued)

LED Flashing Frequency	Possible Cause	Check / Countermeasure	Reference
5  * * * * *	<p>①Push-pull cable installed without proper positioning.</p> <p>②Throttle actuator stroke exceeding stroke of the engine throttle lever.</p> <p>③Throttle actuator set to manual operation.</p> <p>④Loose push-pull cable.</p> <p>⑤Loose connection to engine.</p> <p>⑥No motor motion.</p>	<p>①Perform proper cable positioning &amp; initialization of the throttle actuator.</p> <p>②Reduce throttle actuator stroke.</p> <p>③Set system to NEUTRAL and rotate selector knob to electronic operation.</p> <p>④Fasten cable rod end, lock nuts.</p> <p>⑤Verify engine connection.</p> <p>⑥Consult dealer for replacement item.</p>	<p>Page 33</p> <p>Page 35</p> <p>Page 39</p> <p>Page 32, 39</p>
6  * * * * **	<p>①One of duplex power lines is disconnected.</p> <p>②System power harnesses not properly connected.</p> <p>③Source (battery) voltage outside of operating voltage range.</p> <p>④Power harness damaged.</p> <p>⑤Control unit power line damaged.</p>	<p>①Check/connect both power lines to power source (battery) and turn ON both power line breakers.</p> <p>②Reconnect the system power harnesses to the control unit.</p> <p>③Adjust source (battery) voltage to within specified range.</p> <p>④Consult dealer for power harness replacement .</p> <p>⑤ Consult dealer for replacement item.</p>	<p>Page 24</p> <p>Page 24</p> <p>Page 2</p> <p>Page 24</p>
7  * * * * * * *	<p>①Control head select switch pressed-in or shorted.</p> <p>②Control head sync switch pressed-in or shorted.</p>	<p>Reset/unlock the switch or consult dealer for replacement item.</p>	<p>Page 13</p>
8  * * * * * * * *	<p>①Bus harness damaged</p> <p>②Any T-harness damaged: control head or control unit.</p> <p>③Any T-harness connecting harness damaged: control head 8-pole / 6-pin harness or control unit CAN harness,</p> <p>④optional settings tool setup completed</p>	<p>①Consult dealer for bus harness replacement.</p> <p>②Consult dealer for appropriate T-harness replacement.</p> <p>③Consult dealer for replacement item.</p> <p>④cycle power as per settings tool instructions</p>	<p>Page 21</p> <p>Pages 4-13</p> <p>Pages 4-13</p> <p>Settings tool manual</p>
9  * * * * * * * * *	<p>Option switch pressed-in or shorted. I.e. Idle control switch, Triple switch or Quad switch.</p>	<p>Reset/unlock the switch or consult dealer for replacement item.</p>	<p>Pages 13, 29-31</p>

# TROUBLESHOOTING

Consult this table if problems occur without an associated flashing LED alarm code.

Symptom	Possible Cause	Check / Countermeasure	Reference
No operation even though power source is ON.	Power harness is not connected properly.	Reconnect both power lines to power source (battery) and turn ON both power line breakers.	Page 24
No LED's ON.	①Control head hand lever not in neutral during initial operation. ②R/C-1 T-harness not connected to control head.	① Set hand lever to NEUTRAL position with power ON. ②Connect R/C-1 T-harness.	Page 15 Page 21
F or N or R LED does not light ON.	①Control head LED or CAN harness damaged (connects to T-harness). ②Control head T-harness damaged.	① Consult dealer for replacement item. ②Consult dealer for R/C-1 or R/C T-harness replacement.	Page 13 Page 21
F, N, R LED light ON but shift clutch does not engage.	Shift actuator push-pull cable damaged.	Replace shift actuator push-pull cable.	Page 32
F, N, R LED ON but engine speed does not respond to system.	Throttle actuator push-pull cable damaged.	Replace throttle actuator push-pull cable.	Page 32
Engine does not start.	①Low battery voltage. ②SIGP harness wire too long.	①Charge the battery. ②Shorten SIGP harness wire.	Page 23
Neutral throttle operation not functional.	①Initial control operation not properly set. ②Select switch damaged.	①Perform initial control operation correctly. ② Consult dealer for replacement item.	Page 15 Page 13
Synchronization operation not functional.	①Input signal incorrect. ②Levers more than 10° apart in dual lever mode	① Verify synchronization circuit signal type & connection. ②Adjust levers to be within 10°	Page 25 Page 16

---

# MAINTENANCE AND SERVICE

---

## Control head & Control unit

1. Wash with water and dry to prevent corrosion.
2. Do not apply grease because this assembly contains electronic components.

## Shift & Throttle Actuators

1. Wash with water and dry to prevent corrosion.
2. Apply marine grease to exposed fasteners & moving parts.
3. Check fasteners for looseness periodically.

## Harnesses

1. Check all harnesses for wiring damage periodically.
2. Check all connectors for proper seating periodically.

## Push-pull cables

1. Check push-pull cable connections at both ends (actuator end, engine end) for looseness periodically.
2. Also check push-pull cables for damage, wear, and corrosion periodically.
3. Check for smooth push-pull cable motion while operating levers in each position: Rmax, R, N, F, Fmax; look for signs of backlash or obstructed motion. Verify that there are no alarm codes displayed on the control head panel.
4. In the case of a ball joint type connection to engine lever, carefully inspect abrasion and apply lubricant grease regularly.

Note: Repair or replace any damaged part; consult with dealer.

# CONTROL HEAD TEMPLATE

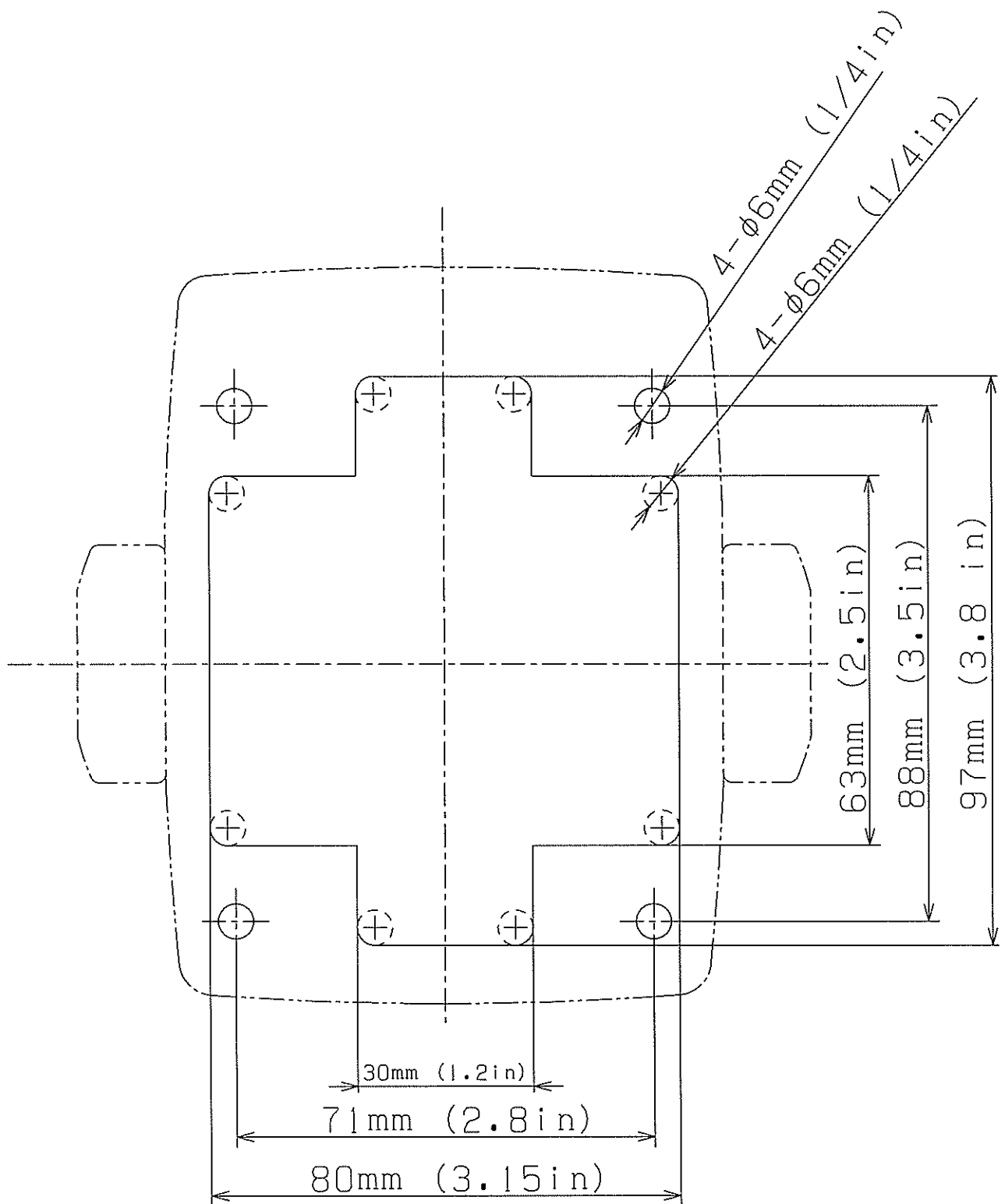

# CONTROL UNIT TEMPLATE

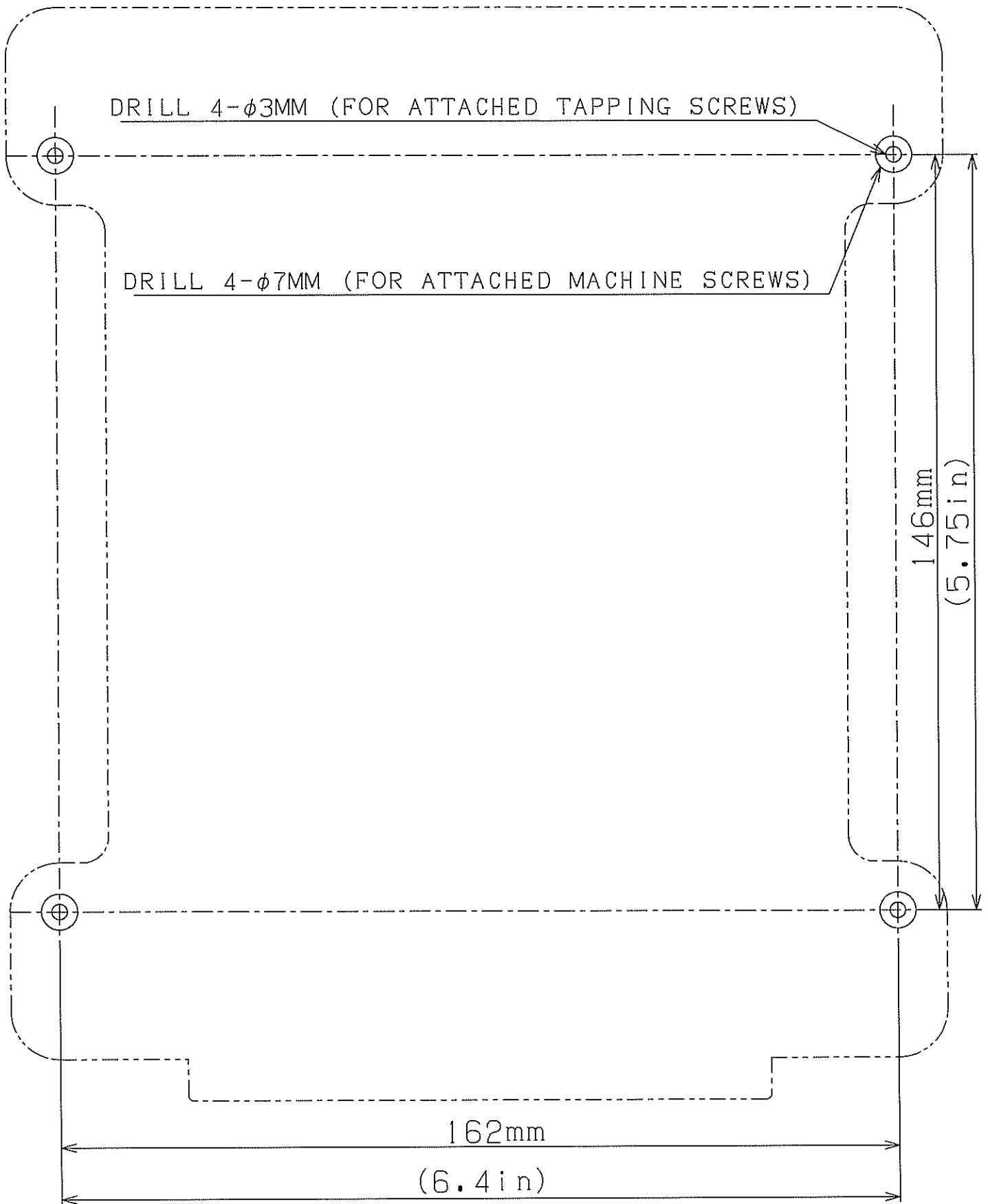

# IDLE / TRIPLE / QUAD / SWITCH TEMPLATE

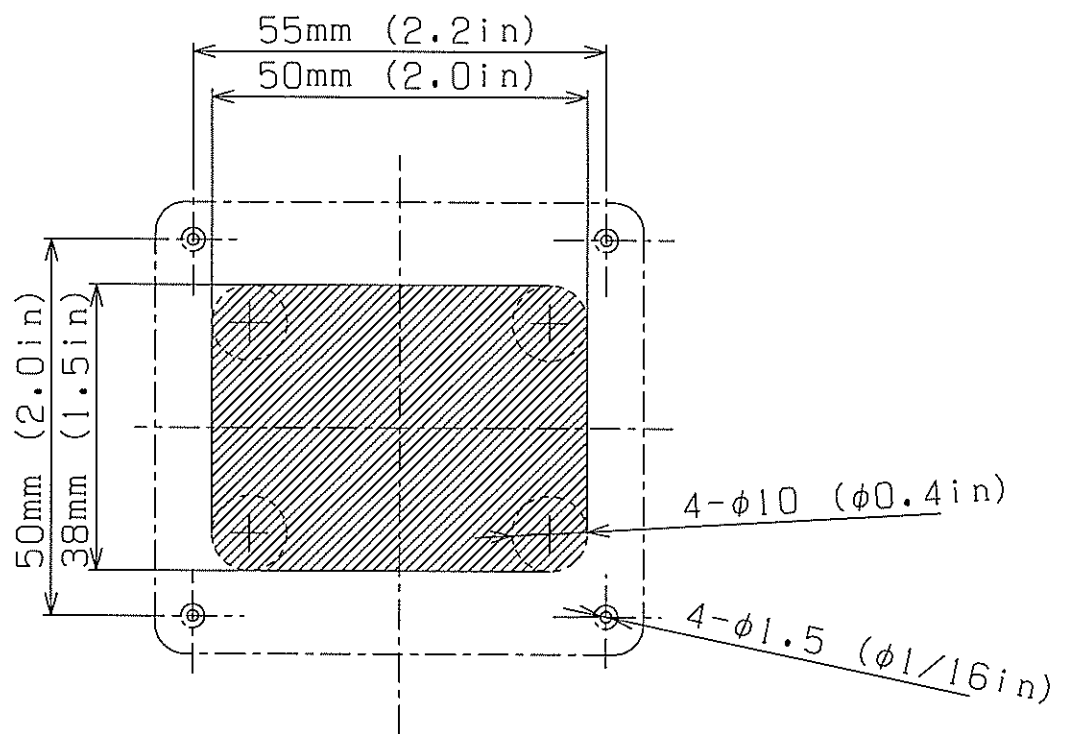

# **NHK MEC Corporation**

**3-21-10, SHIN-YOKOHAMA, KOHOKU-KU, YOKOHAMA,  
222-0033, JAPAN**

**PHONE:+81(45)475-8902      FAX:+81(45)475-8907**

M000169 5B 11.03. PRINTED IN JAPAN COPYRIGHT 2011