

AT A GLANCE

FEATURES

- Pre loaded dual taper bearings ensures minimal excess free play
- Smooth operation and feel
- Shaft seals to prevent water ingress
- 48 degrees of tilt articulation
- 5 positive lock positions
- Up to 3 style options
- Compact footprint
- Maintenance free
- Fits most styled and formed dashes



TILT STEERING

TECHNICAL DATA

The ultimate in Tilt Steering Technology. Tilt Steering delivers unsurpassed performance and flexibility making it the perfect system for all possible applications and boat types.

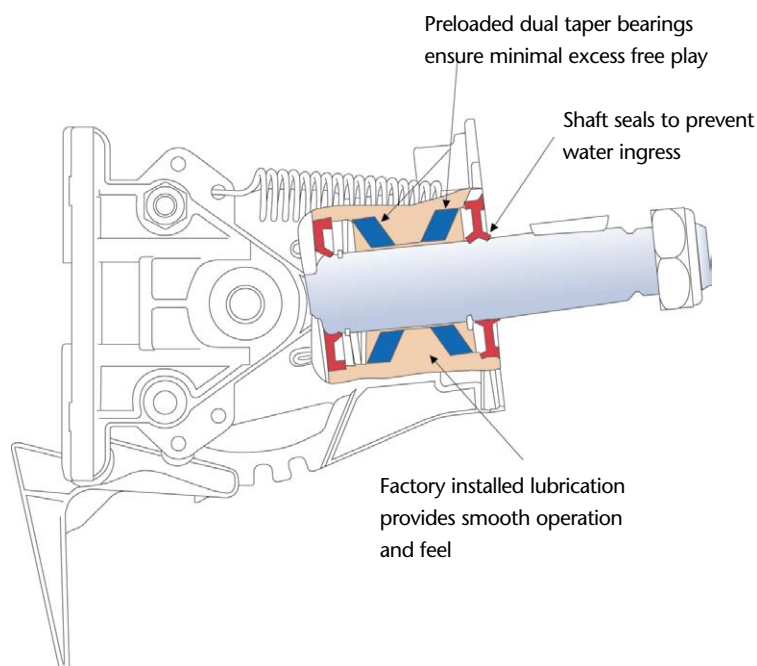

MECHANICAL TILT STEERING

TYPE	COVER STYLE	WHEEL SHAFT	PART NUMBER
Sport	Flexible Rubber Bellows	Taper	SH91800P*
Sport	Flexible Rubber Bellows	Spline	SH91810P*
Sport Plus	Solid Round Cover	Taper	SH91900P*
Sport Plus	Solid Round Cover	Spline	SH91910P*
* Mechanical Tilt mechanism only - select Helm type from list below			
DESCRIPTION (All Helms require Tilt mechanism as shown above)			PART NUMBER
Safe T QC Tilt Helm			SH91523P
Safe T QC - Dual Cable Tilt Helm			SH91524P
Safe T II (NFB) Tilt Helm			SH91190P
4.2 (NFB) Tilt Helm			SH91526P
4.2 (NFB) - Dual Cable Tilt Helm			SH91527P
Rack Tilt Helm			SH91610P
Rack (NFB) Tilt Helm			SH91630P
Pro Rack (NFB) Tilt Helm (Dual Cable)			SH91630P
HPS Tilt Helm			SH91650P
Jet Boat Tilt Helm (135 degree tilt)			SH91691P
Jet Boat Tilt Helm (270 degree tilt)			SH91692P

DASH TILT MODULES

DESCRIPTION	PART NUMBER
NFB Safe-T II	SHT91190
Safe-T QC Single	SHT91523
NFB 4.2 Single	SHT91526
BM Rack	SHT91610
NFB Rack	SHT91630

Includes Tilt Helm & Tilt Mechanism

HYDRAULIC TILT STEERING

COVER TYPE	DISPLACEMENT (CU"-IN)	PRO*	WHEEL SHAFT	PART NUMBER
Sport	1.4	No	Taper	HH4315
Sport	1.7	Yes	Taper	HH6189
Sport	1.7	No	Taper	HH6191
Sport	2.0	No	Taper	HH6145
Sport	2.0	Yes	Taper	HH6190
Sport	2.4	Yes	Taper	HH6188
Sport	2.4	No	Taper	HH6192
Sport Plus	1.7	Yes	Taper	HH6489
Sport Plus	1.7	No	Taper	HH6491
Sport Plus	2.0	Yes	Taper	HH6490
Sport Plus	2.4	No	Taper	HH6492
Classic	1.7	No	Taper	HH6541
Classic	2.4	No	Taper	HH6542

*Pro Helms have a patented lock valve system designed for high torque single outboard applications.

All Tilt Helms listed include the hydraulic helm and tilt mechanism with cover.
Pro helms cannot be used with an un-balanced cylinder.

ISSUE DATE FEB-2010
DATA SHEET NO INT-HS8

Tilt articulation for sport and sport plus (5 Tilt positions)



Tilt articulation for classic (5 Tilt positions)



PAGE 2 OF 2

