

AT A GLANCE

FEATURES

- All controls include start in gear protection
- Designed for use with both universal and OEM shift and throttle cable connections
- Suitable for most boat/dual engine combinations
- Dual action levers (throttle and shift control in each handle)
- Trim, Tilt, options available
- Drag adjustment on all models
- Easy installation and set up
- Includes both chrome and black cover inserts that allow a choice of styling to ensure a perfect aesthetic fit in every application

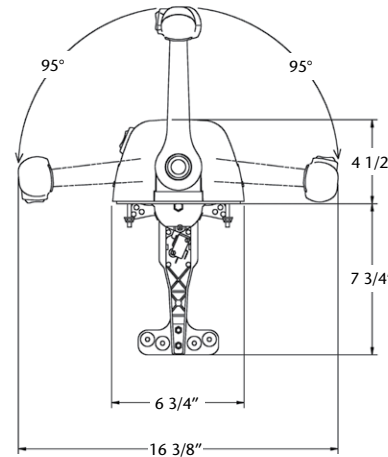
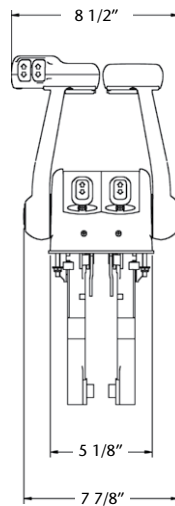

**OSPREY SERIES
CH7800 TOP MOUNT CONTROL**

TECHNICAL DATA

The ergonomics and features of our Osprey Series controls are the most advanced available and are suitable for most kinds of boat/dual engine applications. The shapely, balanced handle provides a very comfortable feel and the state of the art mechanism guarantees a smooth yet solid action, assuring you have maximum control at all times. This control is designed for twin engine applications. CH7800 series of controls are suitable for use with both universal type (3300) or OEM type control cables without the need for adaptation.

SPECIFICATIONS

CH7800 Twin Top Mount

ORDER INFORMATION	COVER	COVER INSERT	HANDLE	TOP CHOICE	PART NUMBER
Base	Chrome	Chrome & Black included	Chrome	√	CH7840
Base with Trim	Chrome	Chrome & Black included	Chrome	√	CH7841
Base with Trim & Tilt	Chrome	Chrome & Black included	Chrome	√	CH7842

